

Secures everything in transit™

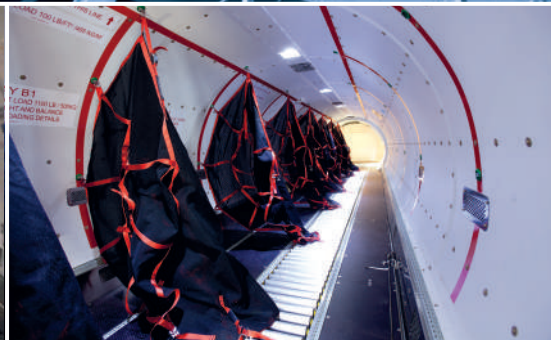

Restraint solutions  
for the aerospace industry

 **GPI forankra**  
CARGO NETS AND RESTRAINT SOLUTIONS

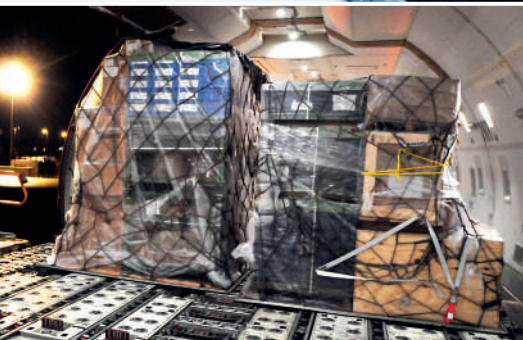

## SOMMAIRE

### Cargo

Cargo pallet net description .....	6
Cargo pallet net advantages .....	7
PMC/PAG light weight cargo net .....	8-9
PLA light weight cargo net .....	8-9
PKC light weight cargo net .....	8-9
PGA/PGF light weight cargo net .....	8-9
Tie down strap ETSO C-172 description .....	10-11
Thermal cover & Fire containment Cover .....	12
Spare parts - vehicule strap / cargo stopper / fitting / security seal / Secu stick .....	13
Microlight harness solution .....	14

### OEM Solutions

Solutions for aircraft manufacturers, tier 1 suppliers and mro companies .....	16
Airframe 9g barrier nets .....	17
Luggage nets.....	18
Custom straps and floor nets.....	19
Tailor made securing solutions .....	20

### Spare parts

Webbings.....	22
Seat track .....	23
Overcenter buckles and cam buckles .....	24
Ratchet buckles .....	25
Slides buckles .....	26
Spare parts .....	27-28

### Military

Cargo securing solution for NH-90 helicopters .....	30
Cargo securing solution for SUPER PUMA AS332 helicopters .....	31
Certified tie down straps ETSO C172 .....	32
Tie down strap for military air transport .....	33
Tie down strap to secure helicopters on aircrafts carrier .....	33
Top & side cargo nets for HCU-6 pallet .....	34
One piece EASA certified cargo net for HCU-6 pallet .....	35
One piece EASA certified cargo net for 2 coupled HCU-6 pallet .....	36
Underslung lifting net .....	37
Easa certified cargo net for PMC/PAG pallet .....	38

### Other products from the Forankra group

Road lashing .....	40
One way securing .....	40
Dock equipment .....	41
Lifting .....	41

## FORANKRA GROUP

Forankra offers products and customized solutions in cargo securing, lifting and cargo optimization through the whole logistic chain – from straps and lashings to technically advanced cargo securing systems for all kinds of road, air and sea transports.

With our knowledge and expertise, we help our customers **to secure everything in transit.**

## GPI FORANKRA

For nearly 40 years, GPI Forankra has been designing, developing and manufacturing all types of cargo restraint systems for the aerospace industry. Our range of products includes ETSO/TSO and STC approved products as well as tailor made solutions:

- >> **Air cargo products:** TSO cargo nets, Tie down Straps, fittings, lashing ropes, thermal covers, spider nets and webbings...
- >> **Aerospace restraint systems:** 9G barrier nets, luggage nets, straps assembly, stow away pockets, fire proof cargo bags...
- >> **Military products:** 9G cargo nets, tie down straps, lifting nets, lifting slings, special fittings...

Our customers:

### >> Air cargo companies and handlers

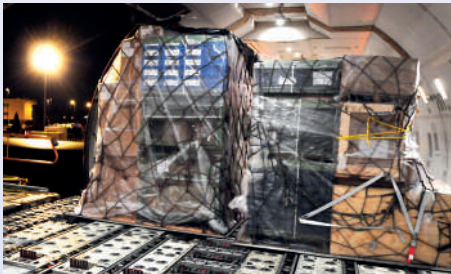

### >> OEM, MRO and Tier 1 suppliers



### >> Air forces, navy, military



## MISSION & VISION

Our mission is to make **handling and transport by air efficient and safe.**

Our vision:

### >> SAFETY

All our products are designed according to the highest international standards to ensure the security of the final users.

### >> QUALITY

Our workers have an average of over 20 years of experience and only use best in class components and material.

### >> FLEXIBILITY

Our workshop is designed to be flexible so that we can propose short lead times and even AOG conditions when necessary.

### >> INNOVATION

Our clients each have specific requirements so innovation is key for our R&D department.

## PRODUCTION IN FRANCE

All our products are manufactured in our own facility in Angers France (**COUNTRY OF ORIGIN: FRANCE**). This gives us total control over the quality of our products and allows us to provide very competitive lead times and prices all over the EMEA area and beyond



## CERTIFICATION

GPI Forankra is fully approved **PART 21 subpart G and certified ISO 9001.**

**PART 21 sub G:** Production Organisation Approval (POA) is managed by EASA. It approves manufacturing process and quality control management of GPI Forankra production.

**ISO 9001:** This certification is a quality management standard. It defines a set of quality management requirements.

**EASA Form 1** certificate can be delivered with all our standard products.

## Cargo

Cargo pallet net description .....	6
Cargo pallet net advantages .....	7
PMC/PAG light weight cargo net .....	8-9
PLA light weight cargo net .....	8-9
PKC light weight cargo net .....	8-9
PGA/PGF light weight cargo net .....	8-9
Tie down strap ETSO C-172 description .....	10-11
Thermal cover & Fire containment Cover .....	12
Spare parts - vehicle strap / cargo stopper / fitting / security seal / Multi-stick .....	13
Microlight harness solution .....	14

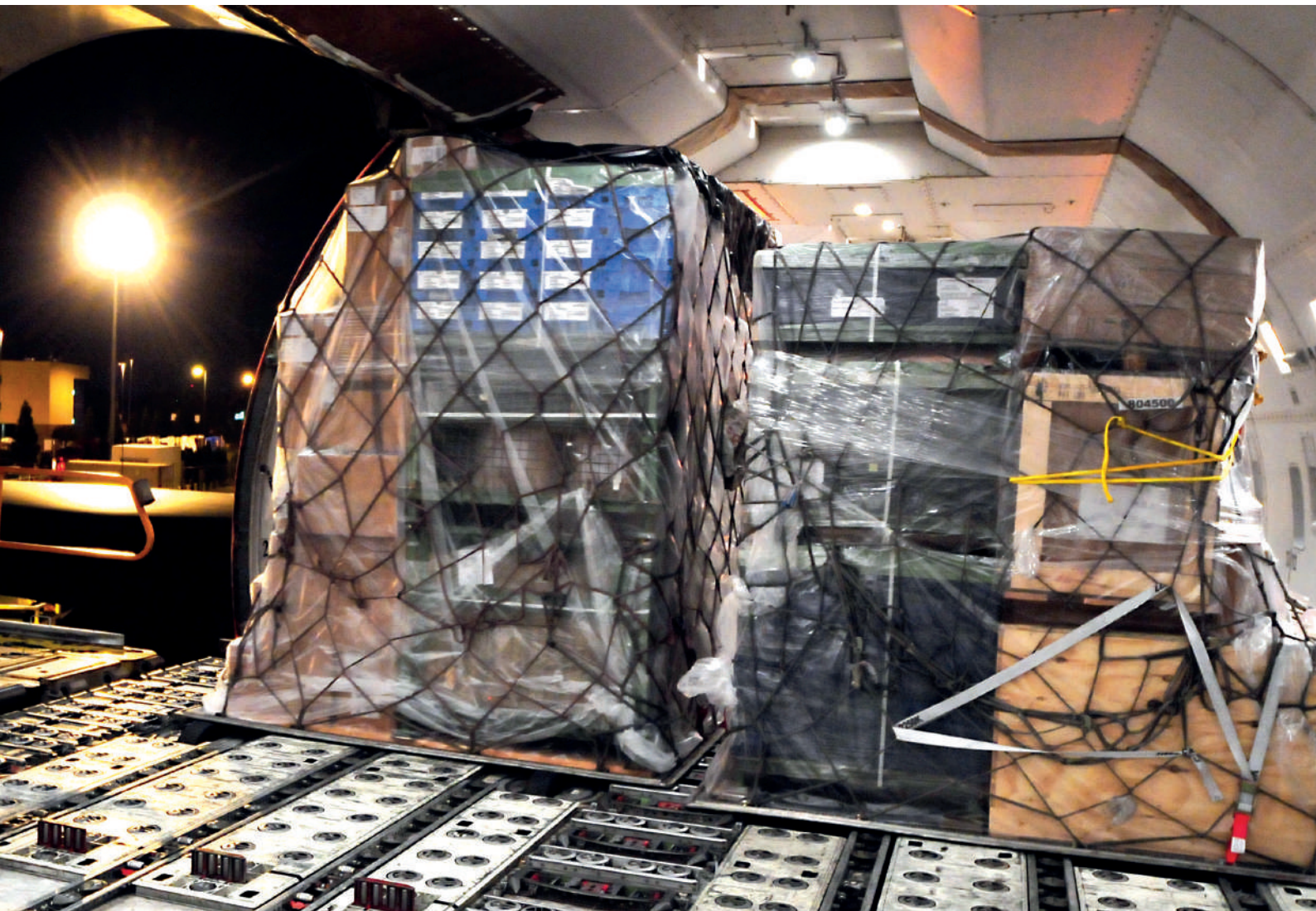

## TSO/ETSO C90C CERTIFIED CARGO PALLET NETS

### A FULL RANGE OF CERTIFIED PRODUCTS

Over the years, the regulation concerning cargo products has evolved and GPI Forankra has always been proactive to certify all its products long before the norms were mandatory.

**>> GPI is a certified Part 21 G organization since 1999 and:**

- All GPI's cargo nets have been designed in compliance with **NAS 3610**.
- All GPI's cargo nets have received a **TSO/ETSO C90c** certification.
- All GPI's tie-down straps were designed in compliance with **ISO 16 049-1**.
- All GPI's tie-down straps have received a **TSO/ETSO C172** certification.



**Component and maintenance manuals (CMM)** are available to our customers and our products are delivered with an **EASA Form 1 certificate**.



### HIGH QUALITY, LOW COST, FLEXIBILITY

GPI is probably the last specialized air cargo restraint manufacturer with full production capacity in Europe. All our products are assembled and inspected in France which gives us total control over quality.

Our optimized production organization allows us to keep our prices very competitive from small and urgent orders to long term larger contracts.

Because we produce on site, we are able to provide short lead times when necessary, even for personalized orders (specific markings, placards, logo...).

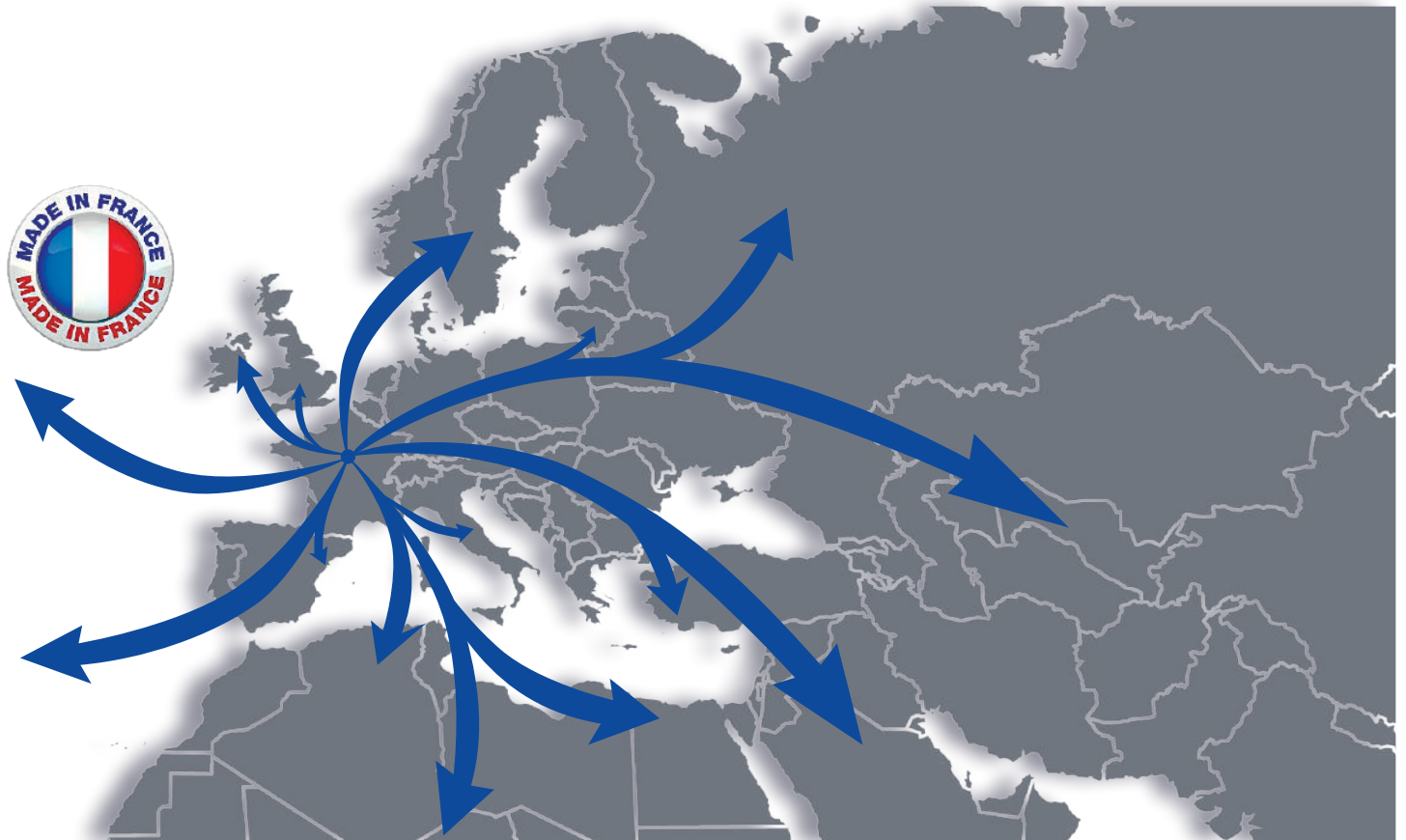

FOCUS ON WEIGHT REDUCTION

**GOOD FOR THE ENVIRONMENT AND YOUR BUDGET**

“The aviation industry pledged to reduce carbon emissions by 50% of 2005 level by 2050 despite an important projected growth.”  
To achieve this, reducing weight in aircrafts is key: today to reduce fuel consumption, tomorrow to allow for electric planes to be viable perhaps.

In order to contribute to this effort, GPI is always pushing to reduce its products' weight.

**Most polyester nets on the market are 50% heavier than our extra light nets**, this represents several hundred kilograms of unnecessary cargo that increase fuel consumption significantly.

In a world where kerosene cost will keep rising, saving 3 to 6kg for each net will not only reduce your company's carbon footprint, but will actually **make you save more money than the actual cost of the net itself over its lifetime!**

**WHY USE LIGHT WEIGHT GPI NETS ?**

According to the FAA, 1kg of extra cargo weight = 100kg of extra fuel consumption each year !

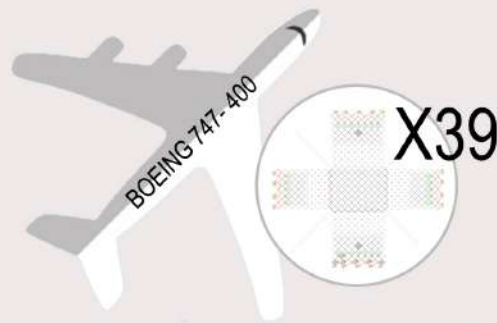

**GPI nets total cost of ownership is actually negative** over their lifetime if you use them to replace standard heavier nets !

*The above figures are based on FAA research, comparing GPI light weight PMC nets with standard 18kg cargo nets, with an average flying time of 3000 hours per year.*

## LIGHT WEIGHT NET EXTRA RANGE

Net to secure your cargo on air cargo pallet.

All components and construction of the pallet net meet the requirements of **IATA standard specification 50/1 and 50/2.**

**Conform to NAS 3610 and approved ETSO/TSO C90c.**

**EASA form 1 certificate / Component and Maintenance Manual (CMM)**

Made of polyester slotted webbing 13mm, with mesh type 250 x 250 mm knotless.

<b>LASHING LINE</b>	4 lashing lines
<b>TENSIONING</b>	24 adjusting hooks
<b>FITTING</b>	18 double studs fittings (5000 lbs) ISO 9788, all drilled for permanent fixture with 3 mm hole
<b>MARKING</b>	2 central placards size 300 x 150 mm with net size, maximum gross weight and pallet type

13 mm Polyester webbing



Tensioning hook



Double stud



Central placard

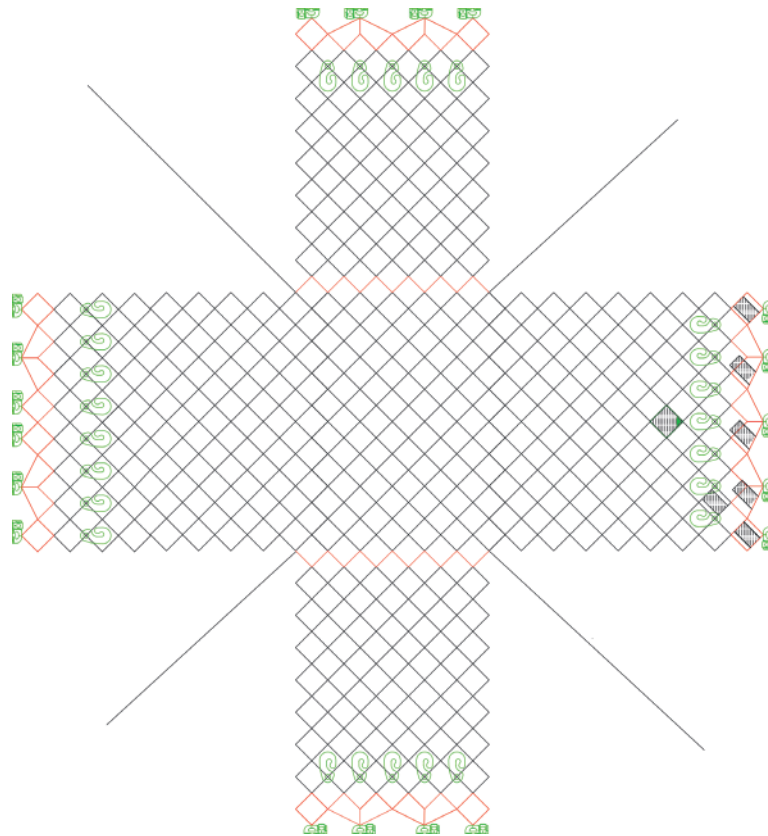

### OPTIONS

Company logo on central placard

Light weight ergonomic hook



ODLN placard



## LIGHT WEIGHT NET EXTRA RANGE



### PMC/PAG CARGO NET

P/N	2M2N-B2-064-30	2M2N-B2-096-30	2M2N-B2-118-30
DIMENSIONS	88/96 x 125 x 64"	88/96 x 125 x 96"	88/96 x 125 x 118"
HEIGHT	64"	96"	118"
WEIGHT	9,4 kg	10,3 kg	11,9 kg

### PLA CARGO NET

P/N	2L3N-064-B1-21	2L3N-064-B1-22
DIMENSIONS	60,4 x 125 x 64"	60,4 x 125 x 80-90"
HEIGHT	64"	80"
WEIGHT	8,2 kg	9 kg

### PKC CARGO NET

P/N	2K3N-064-B1-01	2K3N-064-B1-02
DIMENSIONS	60,4 x 61,5 x 64"	60,4 x 61,5 x 80"
HEIGHT	64"	80"
WEIGHT	6,3 kg	7 kg

### PGA/PGF CARGO NET

P/N	2G1N-096-R2-12	2G1N-096-R2-10
DIMENSIONS	96 x 238,5 x 96"	96 x 238,5 x 118"
HEIGHT	96"	118"
WEIGHT	24 kg	28 kg

Other dimensions available on demand.

All our references pages 42-43

TIE DOWN STRAP ETSO C-172

SLT range - 907 KG / 2000 LBS

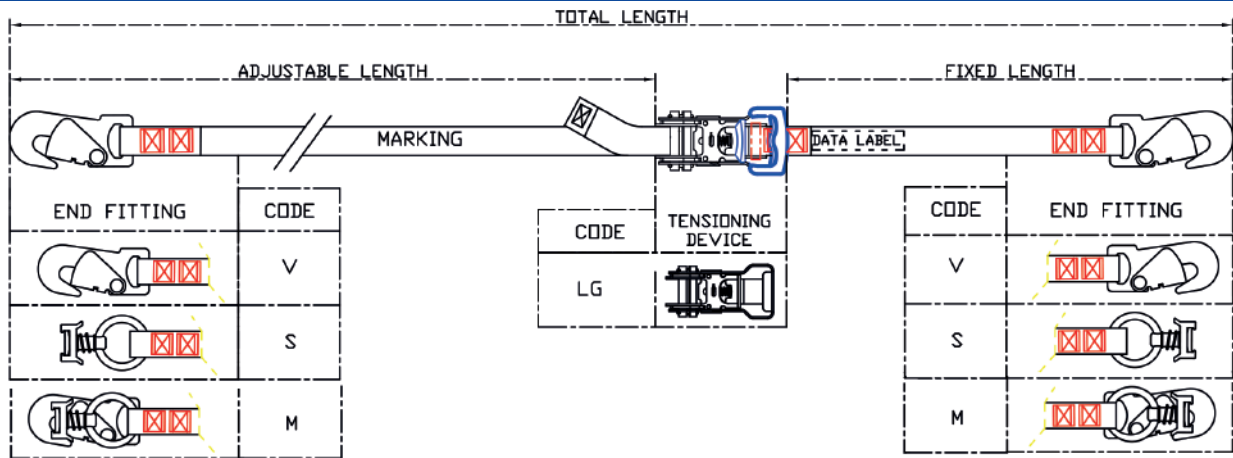

ST range - 2268 KG / 5000 LBS

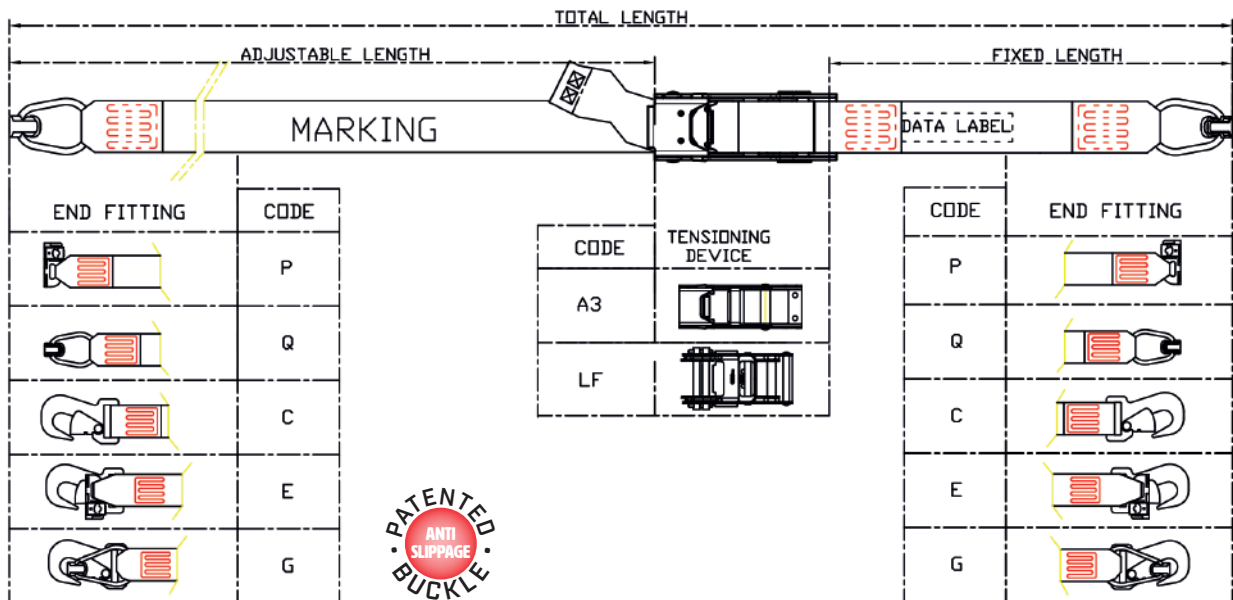

SHT range - 4536 KG / 10 000 LBS

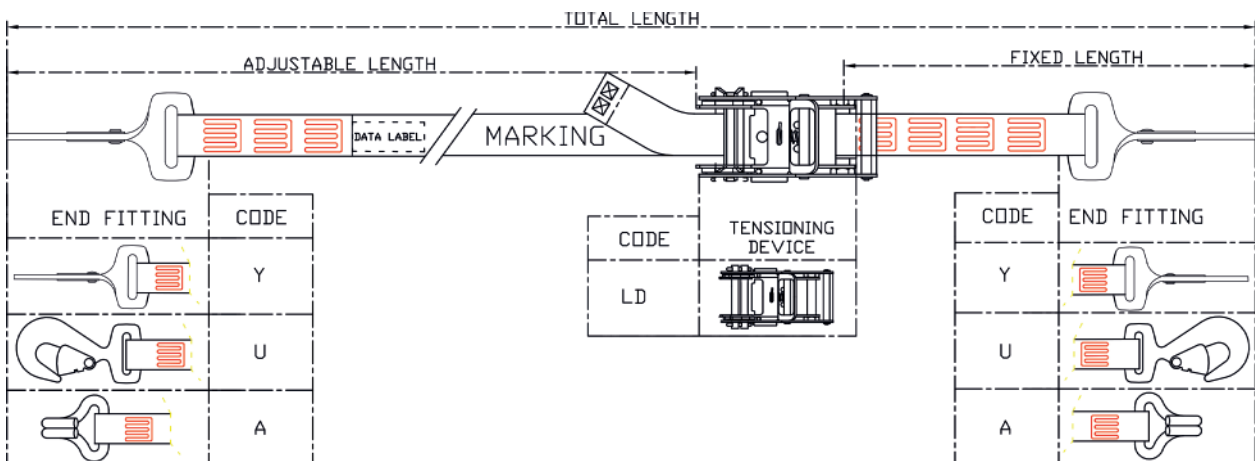

TIE DOWN STRAP ETSO C-172



**TECHNICAL SPECIFICATIONS**

RANGE	SLT	ST	SHT
<b>DESCRIPTION</b>	High quality tie down strap to secure your cargo on air cargo pallet and in aircraft structure		
<b>CERTIFICATION</b>	EASA Certified <b>ETSO C172</b> - Delivered with <b>EASA FORM ONE</b> certificate		
<b>ULTIMATE LOAD</b>	907 kg / 2000 lbs	2268 kg / 5000 lbs	4536 kg / 10 000 lbs
<b>TOTAL LENGTH</b>	Standard: 6, 9, 12 meters - Other length on request		
<b>FIXED LENGTH</b>	Standard: 1 meter - Other length on request		
<b>WEBBING</b>	Polyester - 25 mm width	Polyester - 45 mm width	Polyester - 50 mm width
<b>COLOR</b>	Standard: white, blue, red - Other color on request		
<b>MARKING</b>	On request		
<b>END FITTING</b>	<b>V</b> = Flat snap hook <b>S</b> = Single stud <b>M</b> = Flat snap hook + Single stud	<b>P</b> = Double stud <b>Q</b> = Double stud with ring <b>C</b> = Flat snap hook <b>E</b> = Flat snap hook + Double stud <b>G</b> = Flat snap hook + Double stud with ring	<b>Y</b> = Twisted snap hook <b>U</b> = Flat snap hook <b>A</b> = Double J hook with retainer
<b>TENSIONING DEVICE</b>	<b>LG</b> = Ratchet buckle	<b>A3</b> = Over center buckle <b>LF</b> = Ratchet buckle	<b>LD</b> = Ratchet buckle
<b>LIFE LIMIT</b>	5 years		

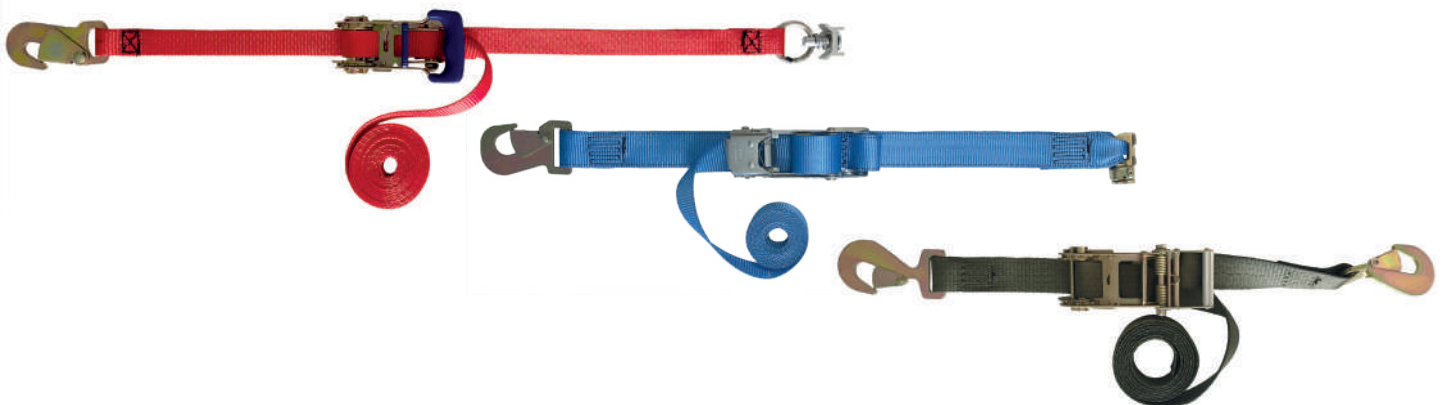

All our references pages 42-43

**THERMAL COVER FOR SEMI FRESH & CEIV PHARMA CARGO**

**P/N: GP TCXXXXXX**

**Secure transport of semi fresh & pharmaceutical product**  
**Compliance: FAR 25 requirements**  
**Easy to install / operate**

**DIMENSIONS:** any pallet size - any height

**Water proof fabric**  
**Closing by velcro**  
**5 sides or 6 sides covers**  
**For temperatures from -30°C to 60°C**

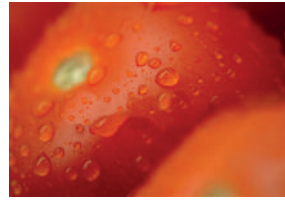

**FIRE CONTAINMENT COVER FOR FLAMMABLE CARGO**

**NSN: 4210-14-563-7900**

**P/N: FCB-096-50**

**Secure transport of flammable product**  
**Compliance: FAR/CS 25 cargo class F**  
**Easy to install / operate**

**DIMENSIONS:** any pallet size - any height

**TIE DOWN FITTINGS:** Single studs or hooks  
**Fire extinguisher holes included**

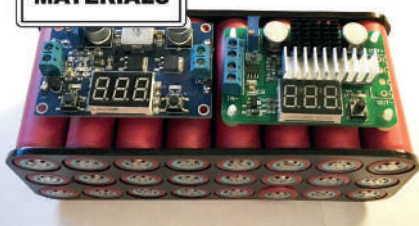
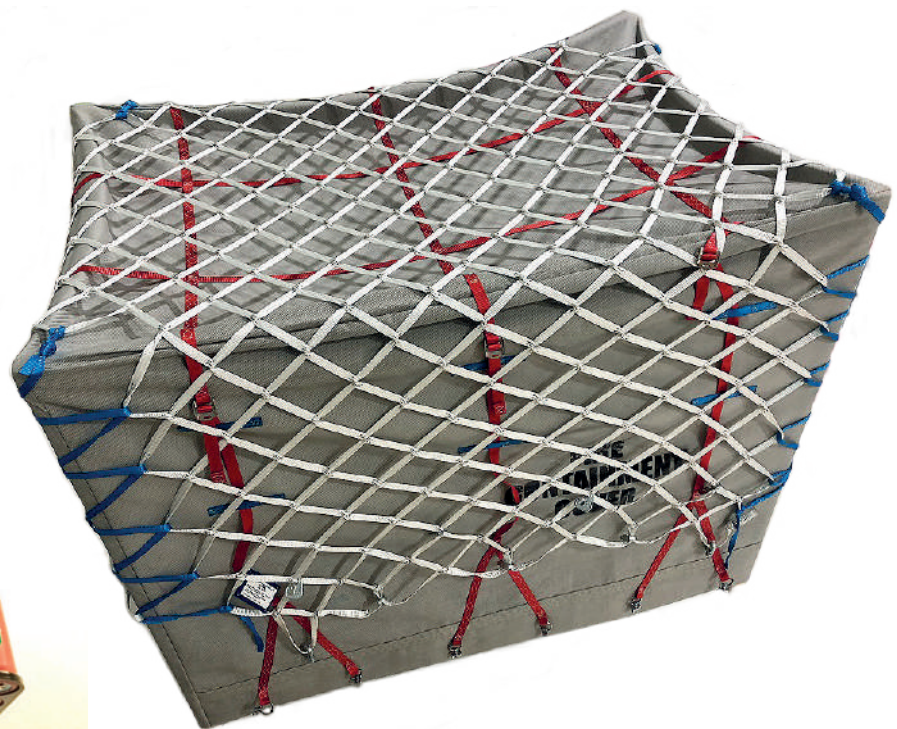

SPARE PARTS

**VEHICULE STRAP - CONFORM FAR25.853**

<b>P/N</b>	<b>SR2PL5-400</b>
<b>ULTIMATE LOAD</b>	2268 kg / 5000 lbs
<b>DIMENSIONS</b>	Ajustable to every wheel dimensions



**CARGO STOPPER - CONFORM SAE AS6022**

<b>P/N</b>	<b>STP 120 / STP 140</b>
<b>ULTIMATE LOAD</b>	2268 kg / 5000 lbs
<b>DIAMETER</b>	1200 / 1400 mm

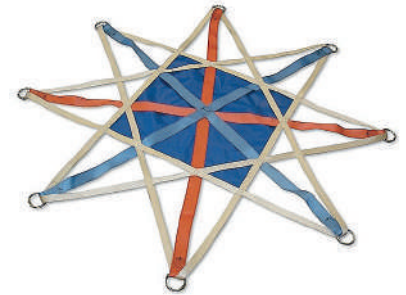

**FITTING - CONFORM ISO**

<b>P/N</b>	<b>FS 700 - Single stud with ring</b>	<b>FS 2000 AP - Double stud with ring</b>
<b>ULTIMATE LOAD</b>	2200 kg / 4850 lbs (vertical)	3300 kg / 7275 lbs (vertical)
<b>CONFORM</b>	ISO 7166	ISO 9788



**SECURITY SEAL**

<b>P/N</b>	<b>PLSCC15-250</b>	<b>PLSCC35-250</b>	<b>PLSCC50-250</b>
<b>DIAMETER</b>	1,5 mm	3,5 mm	5 mm
<b>LENGTH</b>	250 mm		



**MULTI-STICK**

Adjustable pike pole to handle cargo nets

<b>P/N</b>	<b>GP MSSS1030</b>
<b>LENGTH</b>	1 m to 2,70 m
<b>WEIGHT</b>	855 g



All our references pages 42-43

ULTRA LIGHT SAFETY BELT SYSTEMS



From aerospace to microlight.

**HIGHT QUALITY & SECURITY**

GPI Forankra restraint solutions have been developed to fulfill the most demanding safety requirements. Manufactured in France by experienced workers, our products offer the highest quality.

**ULTRA-LIGHT WEIGHT**

For many years, GPI Forankra has focused its R&D efforts on light weight textile restraint solutions for aerospace industry.

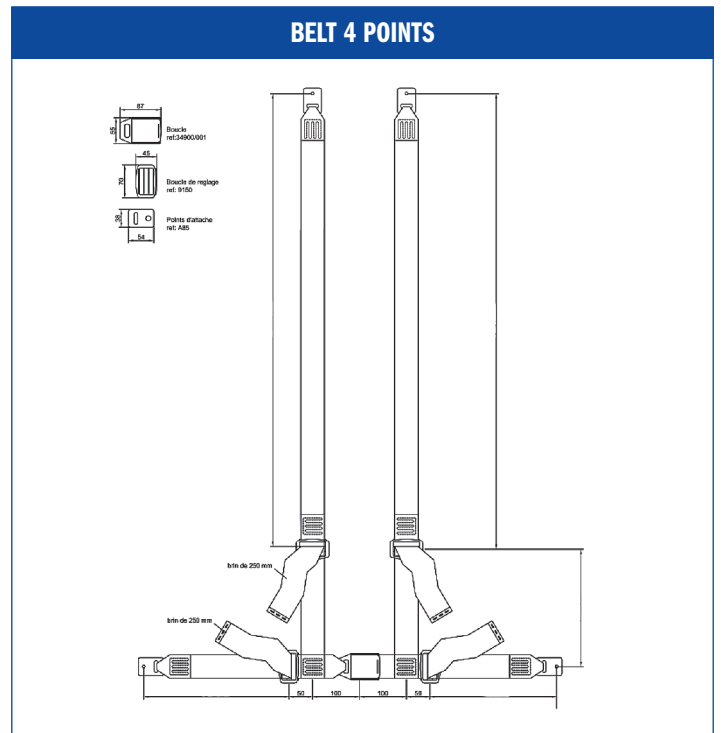
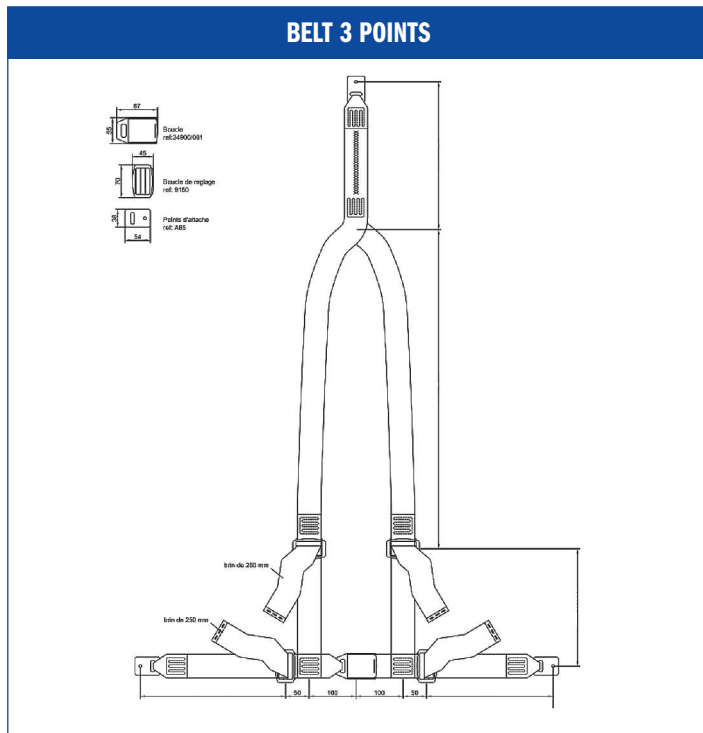

<b>STRAP COLOR</b>	Black, red, grey
<b>BUCKLE</b>	Plane or plastic type
<b>HARDWARE</b>	Plate or ring
<b>MARKING</b>	We can make any marking: compagny name, logo... black and white, color...



Plane type



Plate



Ring

## OEM Solutions

Solutions for aircraft manufacturers, tier 1 suppliers and mro companies .....	16
Airframe 9g barrier nets .....	17
Luggage nets.....	18
Custom straps and floor nets.....	19
Tailor made securing solutions .....	20



SOLUTIONS FOR AIRCRAFT MANUFACTURERS, TIER 1 SUPPLIERS AND MRO COMPANIES

## SECURING ANYTHING THAT FLIES

For over 40 years, GPI has been collaborating with the biggest names in the industry to design and develop tailor made solutions for all types of aircrafts. From stow away pockets in helicopters to 9G barrier nets in cargo planes, we can help you secure anything.



## SUPPORTING YOU ALL THE WAY FROM CONCEPT TO PRODUCT CERTIFICATION

Our international R&D team and our prototyping experts collaborate to propose innovative designs that meet all safety requirements, while minimizing weight and optimizing operations.

We support our clients through the whole certification process, providing all necessary tests reports, material certifications, calculations and justifications to get the product certified by your local regulator.

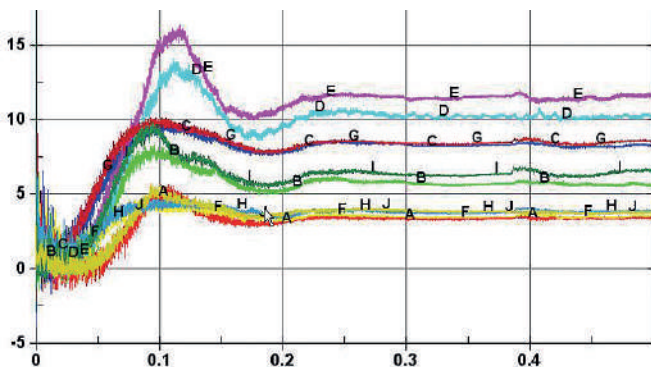
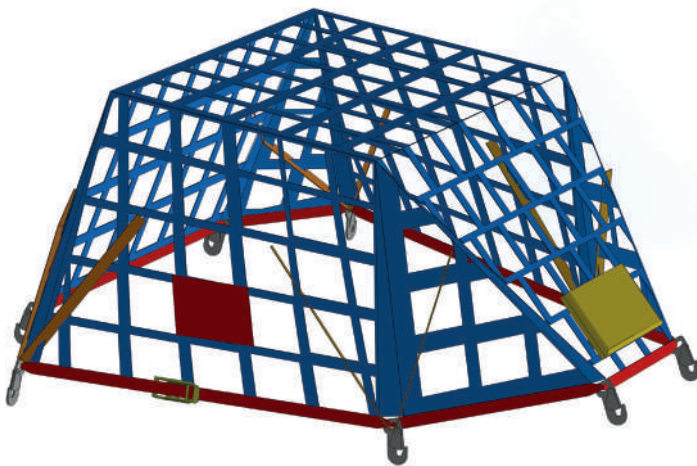

## AIRFRAME 9G BARRIER NETS

GPI has developed 9G barrier nets with clients specialized in cargo conversions. Our range includes nets for ATR and Saab planes and we can propose solutions for any other aircraft.

### ATR 9G BARRIER NET

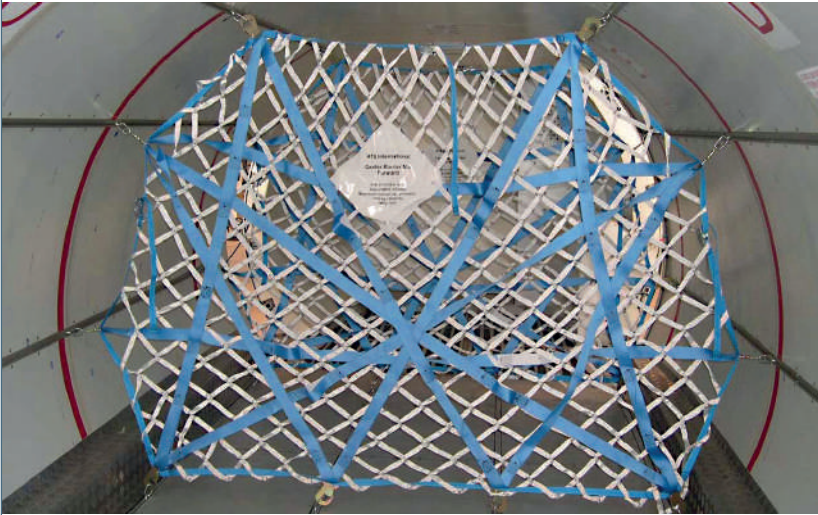

Set of 9G barrier nets for ATR 42 and ATR 72, allowing for the conversion of passenger planes to cargo aircraft. Contains front, center, aft and door nets.

P/N	GPI ref
0110-09-0A-6100EPA	GP AT3000-01
0110-09-0A-6101EPA	GP AT3010-01
9000-01-A-6017-F01EPA	GP AT3017-01
0110-09-0A-6102EPA	GP AT3012
9000-01-A-6018-F01EPA	GP AT3018

### SAAB 9G BARRIER NET

Set of 9G barrier for aircraft such as the Saab 340, allowing for the conversion of passenger planes to cargo aircraft.

Contains forward, door and main cabin nets.

P/N	GPI ref
25-63-10300	GP TA151-6
25-63-10301-2	GP TA156-3
25-63-10299-1	GP TA153-1



## LUGGAGE NETS

From business jets to leisure aircraft, from helicopters to the biggest cargo planes, we have developed all sorts of nets to secure luggage.

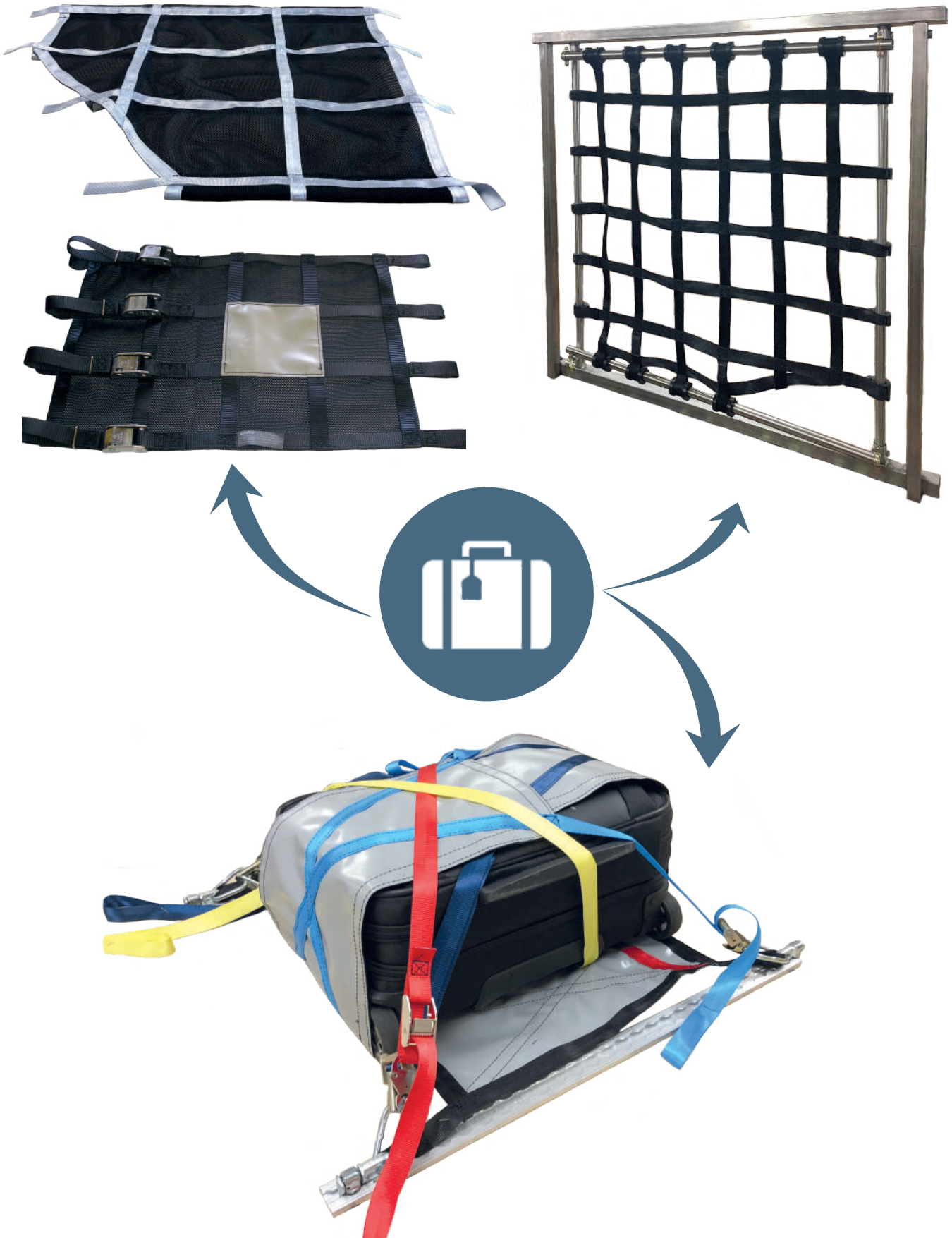

## CUSTOM STRAPS AND FLOOR NETS

Our long experience and wide range of available parts allow us to propose all sorts of custom straps and floor nets to fit your exact need.



## TAILOR MADE SECURING SOLUTIONS

- Strap assembly solution to secure a 1 ton load in an helicopter for stress test flights

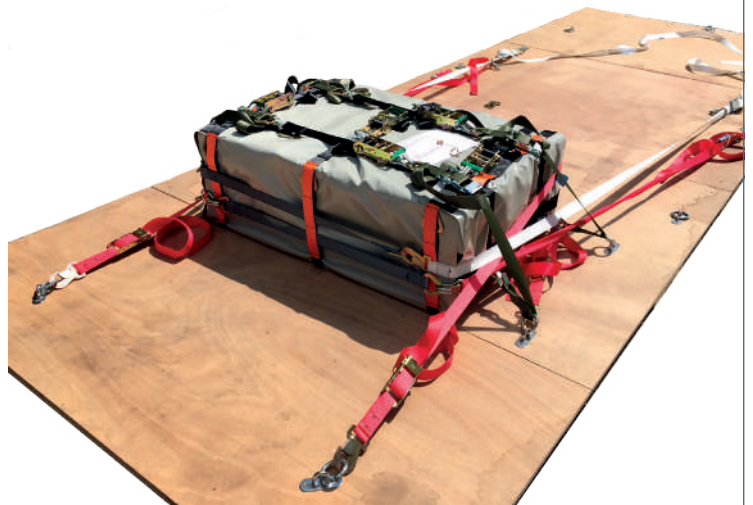

- Special sleeve net, tailor made to secure scientific equipment in a test plane

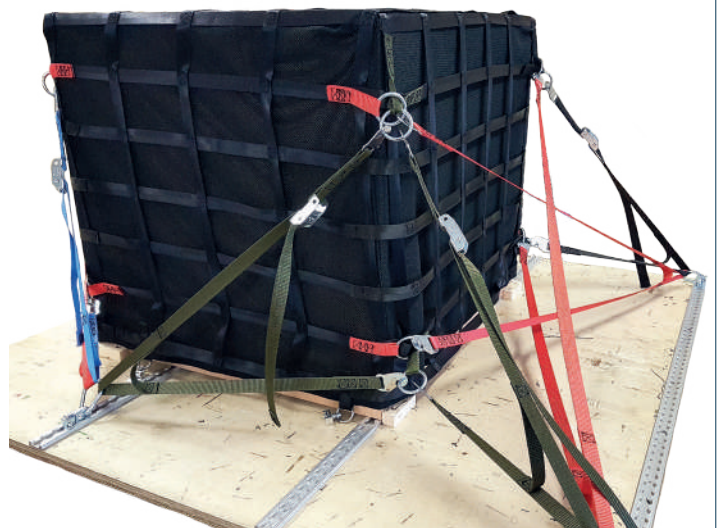

## Spare parts

Webbings.....	22
Seat track .....	23
Overcenter buckles and cam buckles .....	24
Ratchet buckles .....	25
Slides buckles .....	26
Spare parts .....	27-28



**GPI holds in stock a wide range of polyester webbings in different widths, colors and breaking strengths.**

All of them comply with FAR 25 appendix F, and are fully approved for use in an airplane. In addition to our standard range, we can supply almost any other dimensions, breaking strengths or colors.

## SLOTTED WEBBINGS

P/N	723/13 B	723/13 R	723/18
<b>COLORS</b>	White		
<b>WIDTH</b>	13 mm	15 mm	18 mm
<b>MATERIAL</b>	PES		
<b>ULTIMATE LOAD</b>	1250 daN	1500 daN	2000 daN



## FLAT WEBBINGS - 20/45 MM

P/N	1163/20	84 044/25-NO	98 323/25	20 319/25	5264A-044
<b>CONFORMITY WITH</b>	ASNA 3573-5919	ASNA 3573-5926	ASNA 3573-5925	-	-
<b>COLORS</b>	Black	Black	Grey	White, blue, red, grey, green	
<b>WIDTH</b>	20 mm	25 mm	25 mm	25 mm	45 mm
<b>MATERIAL</b>	PES				
<b>ULTIMATE LOAD</b>	700 daN	1200 daN	1200 daN	2000 daN	3100 daN



## FLAT WEBBINGS - 48/75 MM

P/N	84 015/50-NO	85 017/50	94 187/50	93 168/50	6592/60	6551/75
<b>COLORS</b>	Black	Red, blue	White, blue, red, grey, green		Blue, orange, yellow	
<b>WIDTH</b>	48 mm	48 mm	50 mm	50 mm	60 mm	75 mm
<b>MATERIAL</b>	PES					
<b>ULTIMATE LOAD</b>	2500 daN	2500 daN	5000 daN	7500 daN	9000 daN	15 000 daN



## TUBULAR WEBBINGS

P/N	724/15
<b>COLORS</b>	White, blue, red, yellow
<b>WIDTH</b>	15 mm
<b>MATERIAL</b>	PES
<b>ULTIMATE LOAD</b>	1800 daN

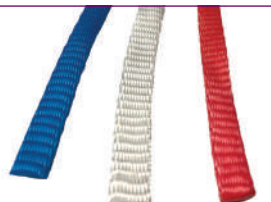

## VELCRO

P/N	APL 800/xx M	APL 800/xx F
<b>CONFORMITY WITH</b>	ASNA 3546-1875	ASNA 3546-1825
<b>COLORS</b>	White, black, grey	
<b>WIDTH</b>	25 mm	



## STRAP PROTECTION SHEATH

P/N	46 137-50	46 137-75
Flat webbing sleeve		
<b>COLORS</b>	PVC	
<b>WIDTH</b>	50 mm	75 mm



All our references pages 42-43

**TARPOLIN**

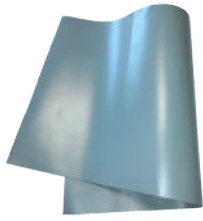

<b>P/N</b>	<b>32 261 A</b>	<b>32 263 B</b>
<b>COLORS</b>	Grey	Blue
<b>MATERIAL</b>	PES	

**RASCHEL NETTING**



<b>P/N</b>	<b>FX 999</b>
<b>COLORS</b>	Black
<b>MATERIAL</b>	Nylon

**SEAT TRACK**

**ANCHOR PLATE**

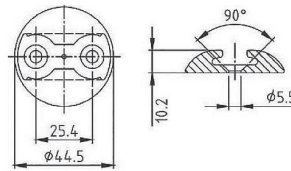

<b>P/N</b>	<b>40000-11</b>	<b>ULTIMATE LOAD</b>	1800 daN
<b>MATERIAL</b>	Aluminium	<b>WEIGHT</b>	20 g

**DOUBLE ANCHOR PLATE**

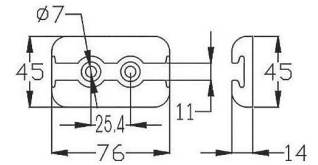

<b>P/N</b>	<b>520 197-40</b>	<b>ULTIMATE LOAD</b>	2500 daN
<b>MATERIAL</b>	Aluminium	<b>WEIGHT</b>	55 g

**SEAT TRACKS**

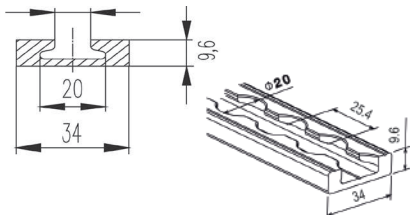

<b>P/N</b>	<b>40 456-10</b>	<b>ULTIMATE LOAD</b>	2000 daN
<b>MATERIAL</b>	Aluminium 7075	<b>WEIGHT</b>	0,57 kg/m

**SEAT TRACKS**

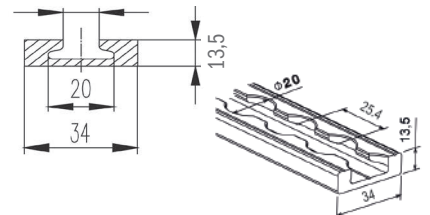

<b>P/N</b>	<b>40 467-11</b>	<b>ULTIMATE LOAD</b>	2700 daN
<b>MATERIAL</b>	Aluminium 7075	<b>WEIGHT</b>	0,9 kg/m

**SEAT TRACKS**

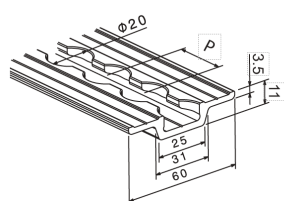

<b>P/N</b>	<b>40 456-51</b>	<b>ULTIMATE LOAD</b>	2000 daN
<b>MATERIAL</b>	Aluminium 6061	<b>WEIGHT</b>	0,92 kg/m

**SEAT TRACKS**

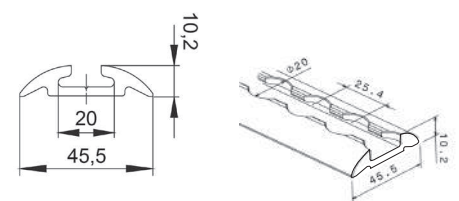

<b>P/N</b>	<b>41 986-2000</b>	<b>ULTIMATE LOAD</b>	1800 daN
<b>MATERIAL</b>	Aluminium 7075	<b>WEIGHT</b>	0,7 kg/m

All our references pages 42-43

OVERCENTER BUCKLES

P/N : 47 800-10

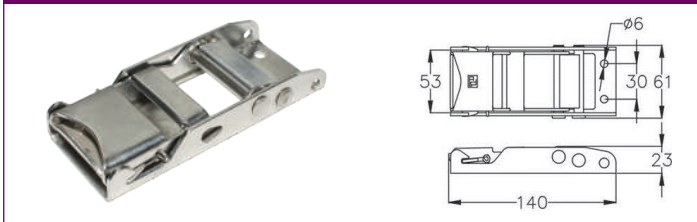

<b>WEBBING</b>	45 mm	<b>ULTIMATE LOAD</b>	2250 daN
<b>MATERIAL</b>	Steel - Zinc plated	<b>WEIGHT</b>	320 g

P/N : 48 857-20



<b>WEBBING</b>	45 mm	<b>ULTIMATE LOAD</b>	2250 daN
<b>MATERIAL</b>	Zinc plated	<b>WEIGHT</b>	435 g

P/N : 46 067-10

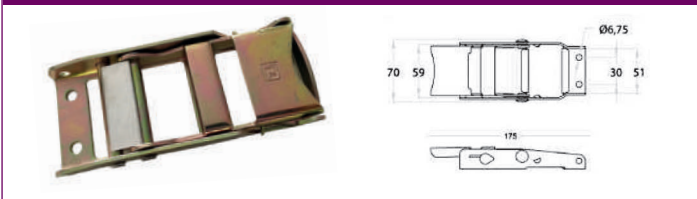

<b>WEBBING</b>	50 mm	<b>ULTIMATE LOAD</b>	800 daN
<b>MATERIAL</b>	Stainless steel	<b>WEIGHT</b>	240 g

P/N : 42 816-20

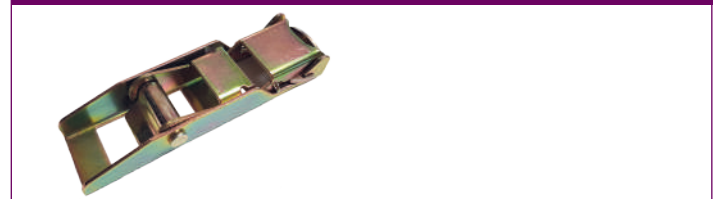

<b>WEBBING</b>	25 mm	<b>ULTIMATE LOAD</b>	2000 daN
<b>MATERIAL</b>	Steel - Zinc plated	<b>WEIGHT</b>	230 g

CAM BUCKLES

P/N : 41 030-17

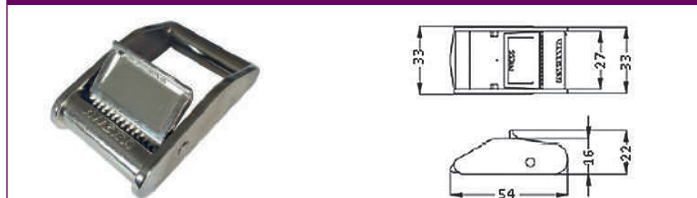

<b>WEBBING</b>	25 mm	<b>ULTIMATE LOAD</b>	250 daN
<b>MATERIAL</b>	Steel - Zinc plated	<b>WEIGHT</b>	60 g

P/N : 48 343-10

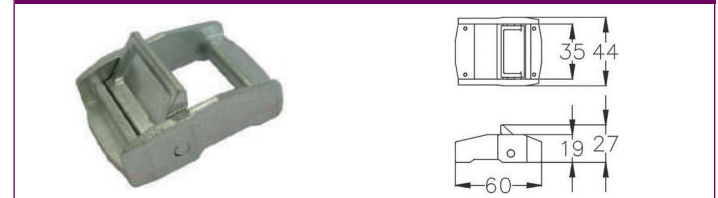

<b>WEBBING</b>	35 mm	<b>ULTIMATE LOAD</b>	700 daN
<b>MATERIAL</b>	Steel	<b>WEIGHT</b>	115 g

P/N : 42 195-10



<b>WEBBING</b>	25 mm	<b>ULTIMATE LOAD</b>	700 daN
<b>MATERIAL</b>	Steel - Zinc plated	<b>WEIGHT</b>	120 g

P/N : 40 880-19

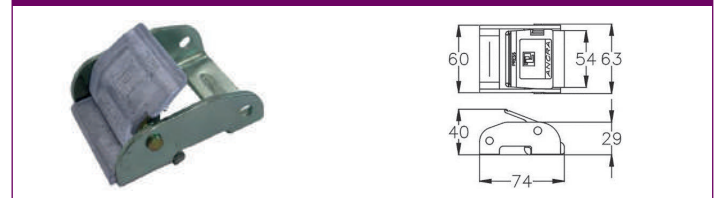

<b>WEBBING</b>	45 mm	<b>ULTIMATE LOAD</b>	1100 daN
<b>MATERIAL</b>	Steel - Zinc plated	<b>WEIGHT</b>	252 g

RATCHET BUCKLES

P/N : 44 232-10

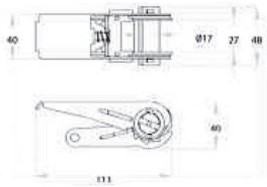
<b>WEBBING</b>	25 mm	<b>ULTIMATE LOAD</b>	750 daN
<b>MATERIAL</b>	Steel - Zinc-plated	<b>WEIGHT</b>	205 g

P/N : 44 232-10 SS





<b>WEBBING</b>	25 mm	<b>ULTIMATE LOAD</b>	750 daN
<b>MATERIAL</b>	Stainless steel	<b>WEIGHT</b>	230 g

P/N : 43 320-12



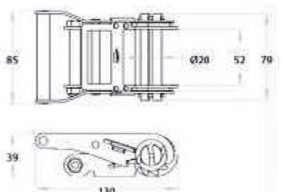

<b>WEBBING</b>	25 mm	<b>ULTIMATE LOAD</b>	2000 daN
<b>MATERIAL</b>	Steel - Zinc plated	<b>WEIGHT</b>	350 g

P/N : 46 405-10

<b>WEBBING</b>	50 mm	<b>ULTIMATE LOAD</b>	5000 daN
<b>MATERIAL</b>	Steel - Zinc plated	<b>WEIGHT</b>	525 g

P/N : 44 627-10

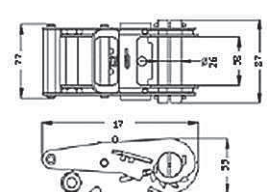
<b>WEBBING</b>	50 mm	<b>ULTIMATE LOAD</b>	5000 daN
<b>MATERIAL</b>	Steel - Zinc plated	<b>WEIGHT</b>	1005 g

P/N : 47 105-17

<b>WEBBING</b>	50 mm	<b>ULTIMATE LOAD</b>	5000 daN
<b>MATERIAL</b>	Stainless steel	<b>WEIGHT</b>	1065 g

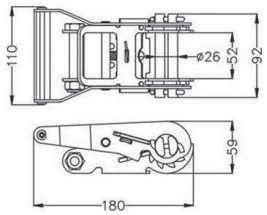
BUCKLE - P/N : 34900/001

		<b>ULTIMATE LOAD</b>	1300 daN
<b>MATERIAL</b>	Nickel - Zinc plated	<b>WEIGHT</b>	140 g

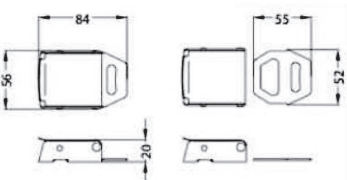
SNAP LATCH - P/N : 45 387-10

<b>WEBBING</b>	25 mm	<b>ULTIMATE LOAD</b>	680 daN
<b>MATERIAL</b>	Steel - Zinc plated	<b>WEIGHT</b>	77 g

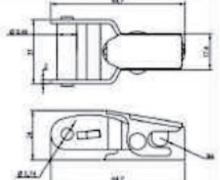
ONE TIME USE LASHING



Contact us for more details

SLIDES BUCKLES

P/N : 8023/25

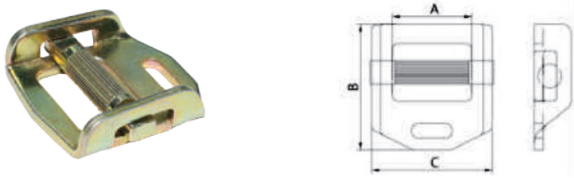

<b>A</b>	<b>B</b>	<b>C</b>	<b>ULTIMATE LOAD</b>	800 daN
26	45	41	<b>WEIGHT</b>	45 g

P/N : 8023/50



<b>A</b>	<b>B</b>	<b>C</b>	<b>ULTIMATE LOAD</b>	900 daN
51	53	68	<b>WEIGHT</b>	110 g

P/N : 34201/251



<b>A</b>	<b>B</b>	<b>C</b>	<b>ULTIMATE LOAD</b>	50 daN
25	14	2,4	<b>WEIGHT</b>	5 g

P/N : 34201/281

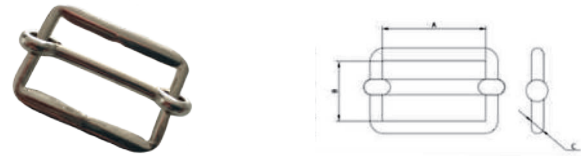

<b>A</b>	<b>B</b>	<b>C</b>	<b>ULTIMATE LOAD</b>	50 daN
28	15	2,7	<b>WEIGHT</b>	8 g

P/N : 34209/271

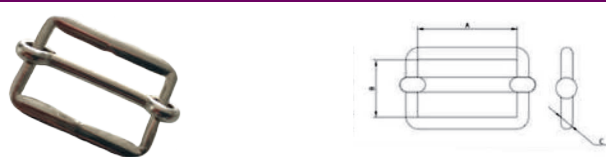

<b>A</b>	<b>B</b>	<b>C</b>	<b>ULTIMATE LOAD</b>	150 daN
27	10	3,9	<b>WEIGHT</b>	14 g

P/N : 34238/154

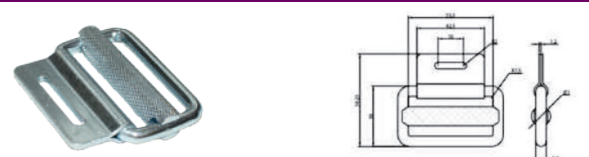

<b>WEBBING</b>	50 mm	<b>ULTIMATE LOAD</b>	800 daN
<b>MATERIAL</b>	Steel - Zinc-plated	<b>WEIGHT</b>	115 g

P/N : 34238/045

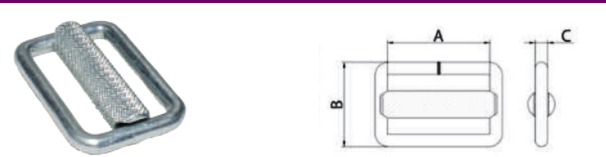

<b>A</b>	<b>B</b>	<b>C</b>	<b>ULTIMATE LOAD</b>	750 daN
45	25	5,9	<b>WEIGHT</b>	71 g

P/N : 34238/054

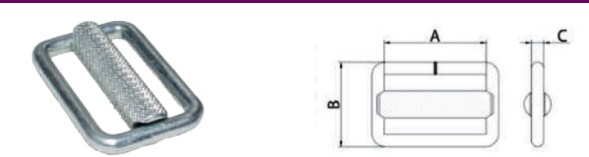

<b>A</b>	<b>B</b>	<b>C</b>	<b>ULTIMATE LOAD</b>	800 daN
54	25	6,4	<b>WEIGHT</b>	85 g

BUCKLE

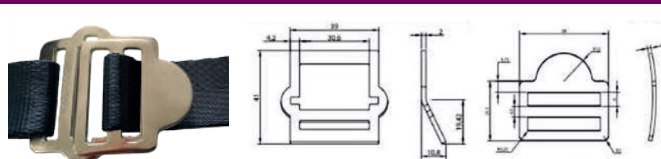

	<b>Female - P/N : 300 B</b>	<b>Male - P/N : 300 C</b>
<b>WEBBING</b>	30 mm	
<b>MATERIAL</b>	Steel - Zinc plated	Steel - Zinc plated
<b>ULTIMATE LOAD</b>	14 g	11 g
<b>WEIGHT</b>	150 daN	

BUCKLE

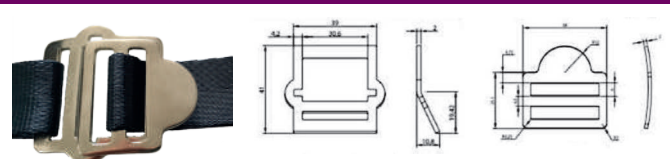

	<b>Female - P/N : 500 B</b>	<b>Male - P/N : 500 C</b>
<b>WEBBING</b>	50 mm	
<b>MATERIAL</b>	Steel - Zinc plated	Steel - Zinc plated
<b>ULTIMATE LOAD</b>	36 g	23 g
<b>WEIGHT</b>	300 daN	

## SPARE PARTS

**P/N : FS 9016**

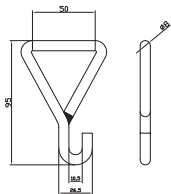

<b>WEBBING</b>	50 mm	<b>ULTIMATE LOAD</b>	1100 daN
<b>MATERIAL</b>	Stainless steel	<b>WEIGHT</b>	95 g

**P/N : FS 5013**

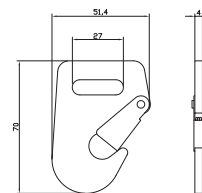

<b>WEBBING</b>	25 mm	<b>ULTIMATE LOAD</b>	900 daN
<b>MATERIAL</b>	Aluminium	<b>WEIGHT</b>	29 g

**P/N : FS 5014**

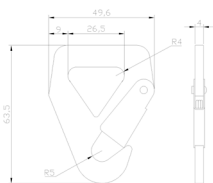

<b>WEBBING</b>	25 mm	<b>ULTIMATE LOAD</b>	450 daN
<b>MATERIAL</b>	Aluminium	<b>WEIGHT</b>	24 g

**P/N : 349010-16**

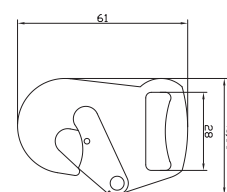

<b>WEBBING</b>	25 mm	<b>ULTIMATE LOAD</b>	1500 daN
<b>MATERIAL</b>	Steel - Zinc plated	<b>WEIGHT</b>	35 g

**P/N : 43 044-11**



<b>WEBBING</b>	25 mm	<b>ULTIMATE LOAD</b>	2300 daN
<b>MATERIAL</b>	Steel - Zinc-plated	<b>WEIGHT</b>	95 g

**P/N : 40 084-14**

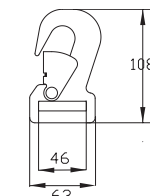

<b>WEBBING</b>	45 mm	<b>ULTIMATE LOAD</b>	3500 daN
<b>MATERIAL</b>	Steel - Zinc plated	<b>WEIGHT</b>	160 g

**P/N : 40 758-10**



<b>WEBBING</b>	50 mm	<b>ULTIMATE LOAD</b>	5000 daN
<b>MATERIAL</b>	Steel - Zinc-plated	<b>WEIGHT</b>	445 g

**P/N : 40 758-11**

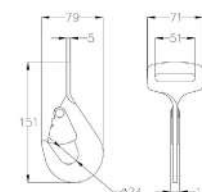

<b>WEBBING</b>	50 mm	<b>ULTIMATE LOAD</b>	5000 daN
<b>MATERIAL</b>	Steel - Zinc plated	<b>WEIGHT</b>	260 g

**P/N : 40 191-XX**



<b>MATERIAL</b>	Steel forging heat treated and plate		
<b>ULTIMATE LOAD</b>	2890 daN	Several height and thread available	

**P/N : FS 5018**

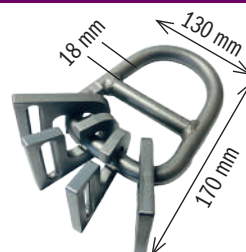

<b>MATERIAL</b>	Inox	<b>ULTIMATE LOAD</b>	10000 daN
<b>WEIGHT</b>	2270 g		

## SPARE PARTS

**P/N : FS 300**

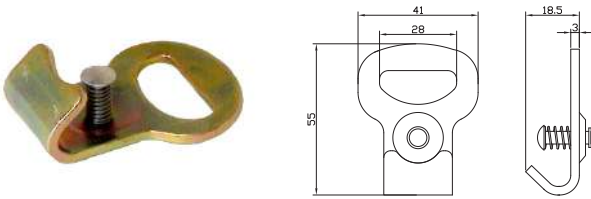

<b>WEBBING</b>	25 mm	<b>ULTIMATE LOAD</b>	1000 daN
<b>MATERIAL</b>	Steel - Zinc-plated	<b>WEIGHT</b>	42 g

**P/N : FS 5010**

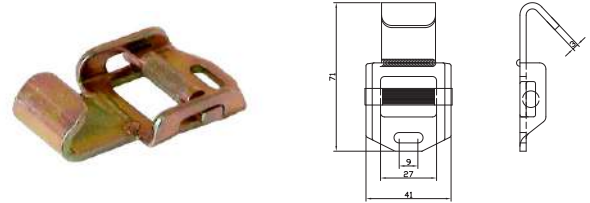

<b>WEBBING</b>	25 mm	<b>ULTIMATE LOAD</b>	800 daN
<b>MATERIAL</b>	Steel - Zinc plated	<b>WEIGHT</b>	74 g

**P/N : FS 5012**



<b>WEBBING</b>	25 mm	<b>ULTIMATE LOAD</b>	800 daN
<b>MATERIAL</b>	Steel - Zinc plated	<b>WEIGHT</b>	100 g

**P/N : 43 977-10**



<b>WEBBING</b>	25 mm	<b>ULTIMATE LOAD</b>	900 daN
<b>MATERIAL</b>	Steel - Zinc plated	<b>WEIGHT</b>	16 g

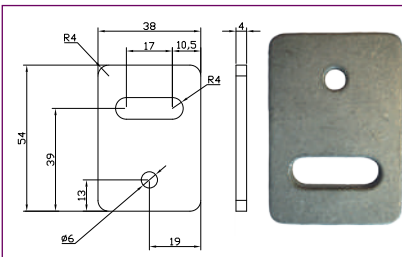

P/N	A83	A85	A85-01	A82	A84-50
<b>WEBBING</b>	25 mm				50 mm
<b>MATERIAL</b>	Steel - Zinc plated	Aluminium		Steel black coated	Steel - Zinc plated
<b>ULTIMATE LOAD</b>	1000 daN	800 daN		900 daN	1200 daN
<b>WEIGHT</b>	57 g	20 g		41 g	103 g

## SPECIAL FINISHES AND TREATMENTS

For a simple question of look or for technical reasons, most of our parts may be delivered, on request, with special finishes and treatments.

Gold plated, nickel plated, zinc plated....

ask our technical department for all possible solutions.



## Military

Cargo securing solution for NH-90 helicopters .....	30
Cargo securing solution for SUPER PUMA AS332 helicopters .....	31
Certified tie down straps ETSO C172 .....	32
Tie down strap for military air transport .....	33
Tie down strap to secure helicopters on aircrafts carrier .....	33
Top & side cargo nets for HCU-6 pallet .....	34
One piece EASA certified cargo net for HCU-6 pallet .....	35
One piece EASA certified cargo net for 2 coupled HCU-6 pallet .....	36
Underslung lifting net .....	37
Easa certified cargo net for PMC/PAG pallet .....	38



## CARGO SECURING SOLUTION FOR NH-90 HELICOPTERS

### CARGO NET + TIE DOWN STRAP

<b>P/N</b>	<b>GP GAM161613</b>
<b>NSN</b>	<b>1670-14-578-9654</b>
<b>DIMENSIONS</b>	1970 x 1500 x 1300 mm
<b>TARE WEIGHT</b>	16 kg / 35 lbs
<b>HEIGHT</b>	Adjustable from 0 to 1300 mm
<b>ULTIMATE LOAD</b>	1000 kg
<b>TENSION</b>	6 tie down straps

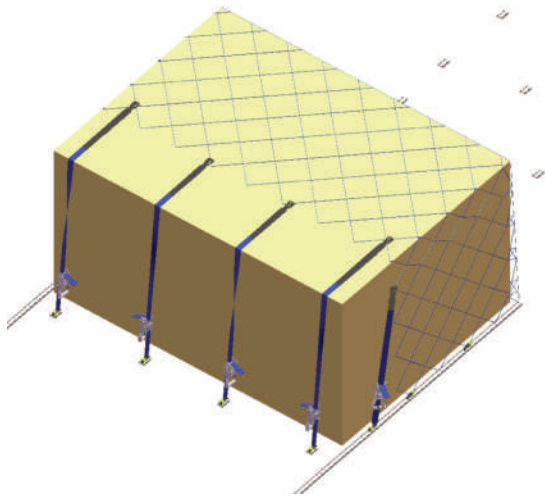

### FLOOR FITTING

**NSN : 1670-14-578-9663**

**P/N : FS 2000 AP**

**Double stud with ring**



### TIE DOWN STRAP 2250 KG / 5000 IBS

<b>P/N</b>	<b>SMGGLA04005</b>
<b>NSN</b>	<b>1680-14-578-9659</b>
<b>CONFORMITY</b>	ISO 16 049-1
<b>ULTIMATE LOAD</b>	2268 kg / 5000 lbs
<b>ADJUSTABLE LENGTH</b>	mini 0,5 m - maxi 4 m
<b>WIDTH</b>	35 mm
<b>WEBBING</b>	High tenacity polyester, FAR 25.853
<b>COLOUR</b>	Military green
<b>TENSIONING DEVICE</b>	Ratchet buckle 35 mm
<b>END FITTING</b>	Double J hook with retainer (both sides)

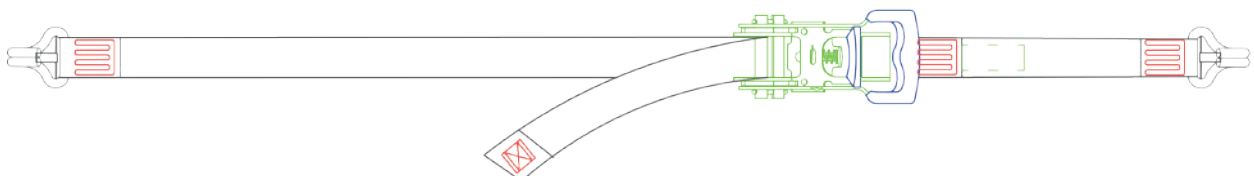

## CARGO SECURING SOLUTION FOR SUPER-PUMA AS332 HELICOPTERS

- >> Direct fitting on OEM floor cargo rings
- >> 2 different nets: front & rear cargo compartment
- >> Adjustable to any size and shape of cargo
- >> Total maximum load: 600kg (300 kg per net)
- >> STC certification n° 10037327
- >> Delivered with EASA Form one



FRONT CARGO COMPARTMENT NET	
Direct fitment on OEM floor attachments	
P/N	GP EUFR225ZA-10
NSN	TBD
DIMENSIONS	1750 x 1840 x 1250 mm
TARE WEIGHT	15 kg / 33 lbs
HEIGHT	Adjustable from 0 to 1250 mm
ULTIMATE LOAD	300 kg

REAR CARGO COMPARTMENT NET	
Direct fitment on OEM floor attachments	
P/N	GP EUFR225ZB-10
NSN	TBD
DIMENSIONS	1490 x 1440 x 1250 mm
TARE WEIGHT	15 kg / 33 lbs
HEIGHT	Adjustable from 0 to 1250 mm
ULTIMATE LOAD	300 kg

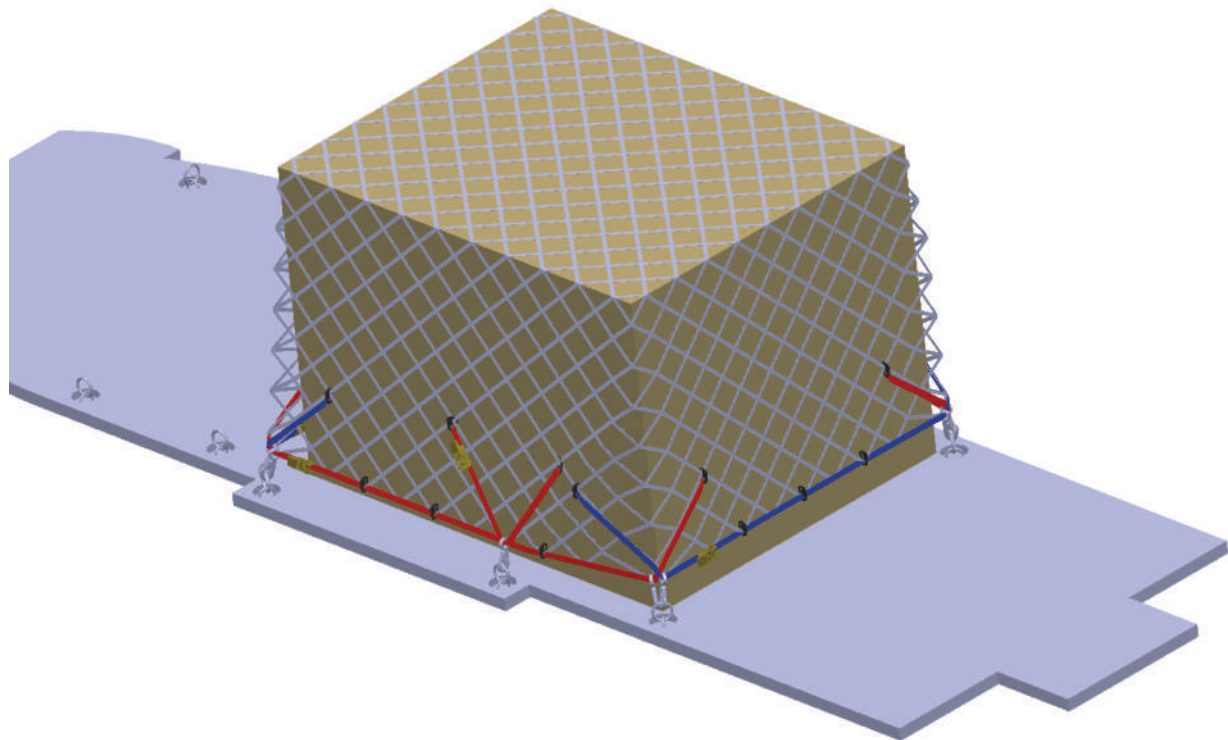

**TIE DOWN STRAP ETSO C172**



**P/N : SLT RANGE**

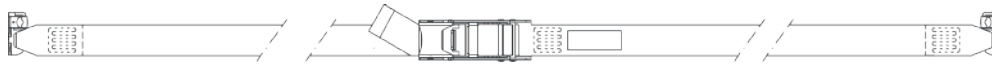

**P/N : ST RANGE**

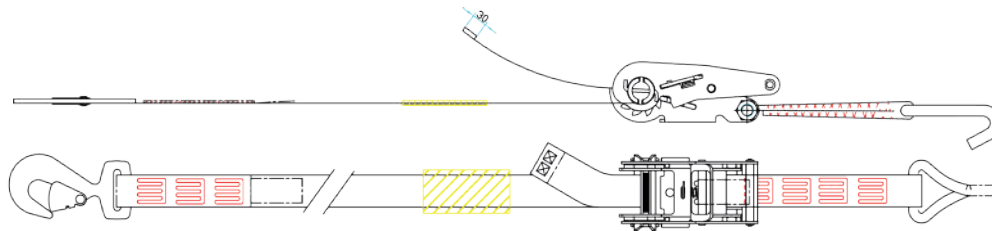

**P/N : SHT RANGE**

RANGE	SLT	ST	SHT
NSN	TBD	TBD	TBD
DESCRIPTION	High quality tie down strap to secure your cargo on air cargo pallet and in aircraft structure		
CERTIFICATION	EASA Certified <b>ETSO C172</b> - Delivered with <b>EASA FORM ONE</b> certificate		
ULTIMATE LOAD	907 kg / 2000 lbs	2268 kg / 5000 lbs	4536 kg / 10 000 lbs
TOTAL LENGTH	Standard: 6, 9, 12 meters - Other length on request		
FIXED LENGTH	Standard: 1 meter - Other length on request		
WEBBING	Polyester - 25 mm width	Polyester - 45 mm width	Polyester - 50 mm width
COLOR	Standard: Military green - Other color on request		
END FITTING	<b>V</b> = Flat snap hook <b>S</b> = Single stud <b>M</b> = Flat snap hook + Single stud	<b>P</b> = Double stud <b>C</b> = Flat snap hook <b>Q</b> = Double stud with ring <b>E</b> = Flat snap hook + Double stud <b>G</b> = Flat snap hook + Double stud with ring	<b>Y</b> = Twisted snap hook <b>U</b> = Flat snap hook <b>A</b> = Double J hook with retainer
TENSIONING DEVICE	<b>LG</b> = Ratchet buckle	<b>A3</b> = Over center buckle <b>LF</b> = Ratchet buckle	<b>LD</b> = Ratchet buckle
LIFE LIMIT	5 years		

**TIE DOWN STRAP FOR MILITARY AIR-TRANSPORT**



P/N : SIPPL206010-AR



P/N : SIC0L406000



P/N	SIPPL206010-AR	SIC0L406000
NSN	TBD	3940-14-562-4258
CONFORMITY	ISO 16 049-1	MIL-PRF-27260C
ULTIMATE LOAD	2268 kg / 5000 lbs	
TOTAL LENGTH	Maxi 6 meter	
WIDTH	45 mm	50 mm
WEBBING	High tenacity Polyester FAR 25.853	
COLOR	Military green	White
END FITTING	Flat hook with retainer + double stud fitting (both sides)	Double J hook
TENSIONING DEVICE	Ratchet buckle 45 mm	Ratchet buckle 50 mm
LIFE LIMIT	3 years	

**TIE DOWN STRAP TO SECURE HELICOPTERS ON AIRCRAFT CARRIER**



P/N : SHZZLC04003

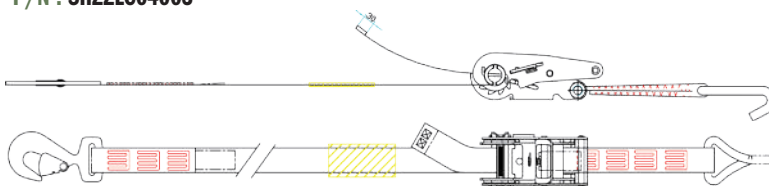

P/N : SHTZILD07003-MIL



P/N	SHZZLC04003	SHTZILD07003-MIL
NSN	TBD	1730-14-5887257
CONFORMITY	ISO 16 049-1	ISO 16 049-1 / ETSO C172
ULTIMATE LOAD	4536 kg / 10 000 lbs	
TOTAL LENGTH	3 to 7 meters	
WIDTH	50 mm	
WEBBING	High tenacity Polyester FAR 25.853	
COLOR	Most colours available	
END FITTING	Reinforced flat hook and/or J hook	
TENSIONING DEVICE	Over center buckle	Ratchet Buckle

TOP & SIDE CARGO NETS FOR 463L / HCU-6 PALLET

TOP PALLET NET HCU-15/C

<b>P/N</b>	<b>GP AR2015-01</b>
<b>NSN</b>	<b>1670-14-536-6275</b>
<b>CONFORMITY</b>	<b>MIL-N-27444D</b>
<b>ULTIMATE LOAD</b>	4536 kg / 10 000 lbs
<b>DIMENSIONS</b>	185" x 166"
<b>MESH DIMENSIONS</b>	250 x 250 mm
<b>WEBBING</b>	100% Polyester - FAR 25.853 + anti abrasion treatment
<b>COLOR</b>	Yellow sand
<b>TARE WEIGHT</b>	17 kg / 38 lbs

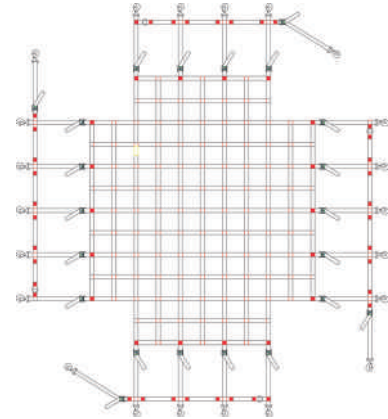

SIDE PALLET NET HCU-7/C

<b>P/N</b>	<b>GP AR2010-01</b>
<b>NSN</b>	<b>1670-14-536-6277</b>
<b>CONFORMITY</b>	<b>MIL-N-2744</b>
<b>ULTIMATE LOAD</b>	4536 kg / 10 000 lbs
<b>DIMENSIONS</b>	195,5" x 65,5"
<b>MESH DIMENSIONS</b>	300 x 300 mm
<b>WEBBING</b>	100% Polyester - FAR 25.853 + anti abrasion treatment
<b>COLOR</b>	Olive drab
<b>TARE WEIGHT</b>	15 kg / 33 lbs

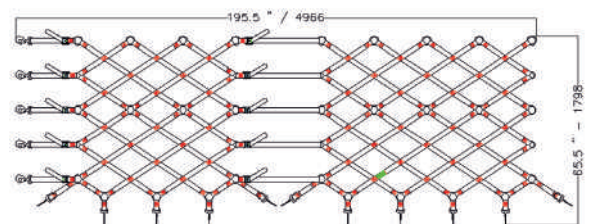

ONE PIECE EASA CERTIFIED CARGO NETS FOR 463L / HCU-6 PALLET

CARGO NET FOR HCU-6 PALLET

<b>P/N</b>	<b>1B6N-N3-096-12</b>
<b>NSN</b>	<b>1670-14-563-2143</b>
<b>DIMENSIONS</b>	88" x 108" x 96"
<b>DESIGN REQUIREMENT</b>	<b>Conform to NAS 3610 and approved ETSO/TSO C90c</b>
<b>DOCUMENTATION</b>	EASA certification n° EASA.210.1234
<b>WEBBING</b>	100% Polyester ; FAR 25.853 + anti abrasion treatment
<b>MESH TYPE</b>	Knotless mesh
<b>TARE WEIGHT</b>	32 kg / 70,5 lbs
<b>ULTIMATE LOAD</b>	4536 kg / 10.000 lbs
<b>LIFESPAN</b>	10 years storage, 5 years in use

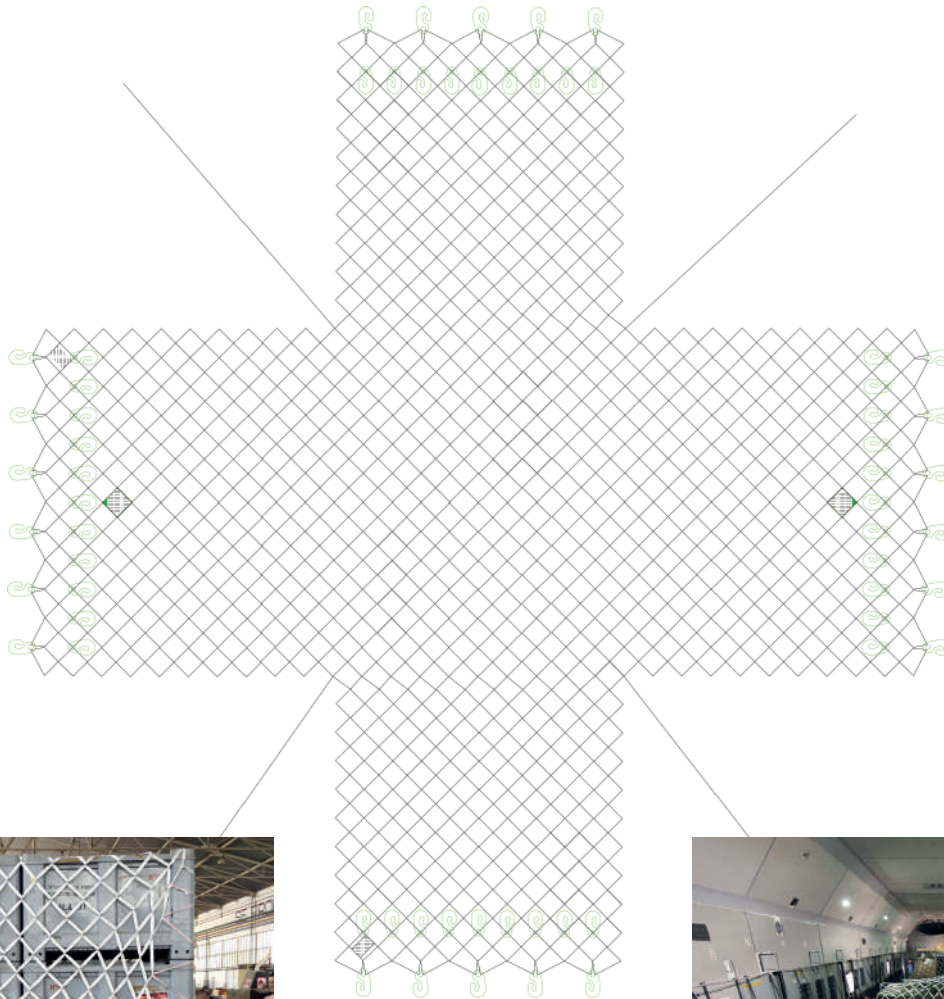

## ONE PIECE CARGO NETS FOR 2 COUPLED 463L / HCU-6 PALLET

### CARGO NET FOR 463L / HCU-6 DOUBLED

<b>P/N</b>	<b>1B6N-N3-096-10</b>
<b>NSN</b>	<b>1670-14-581-2298</b>
<b>DESIGN REQUIREMENT</b>	<b>Based on NAS 3610</b>
<b>ULTIMATE LOAD</b>	Depends on W&B manual of the aircraft and the pallet + coupler used. Recommended max 13750 lbs
<b>DIMENSIONS</b>	108" x 178" x 96"
<b>TARE WEIGHT</b>	44 kg / 97 lbs
<b>WEBBING</b>	100% Polyester - FAR 25.853
<b>NUMBER OF TIE DOWN HOOKS</b>	32 pcs
<b>NUMBER OF AJUSTING HOOKS</b>	52 pcs
<b>MESH TYPE</b>	Knotless
<b>MESH DIMENSIONS</b>	180 x 180 mm

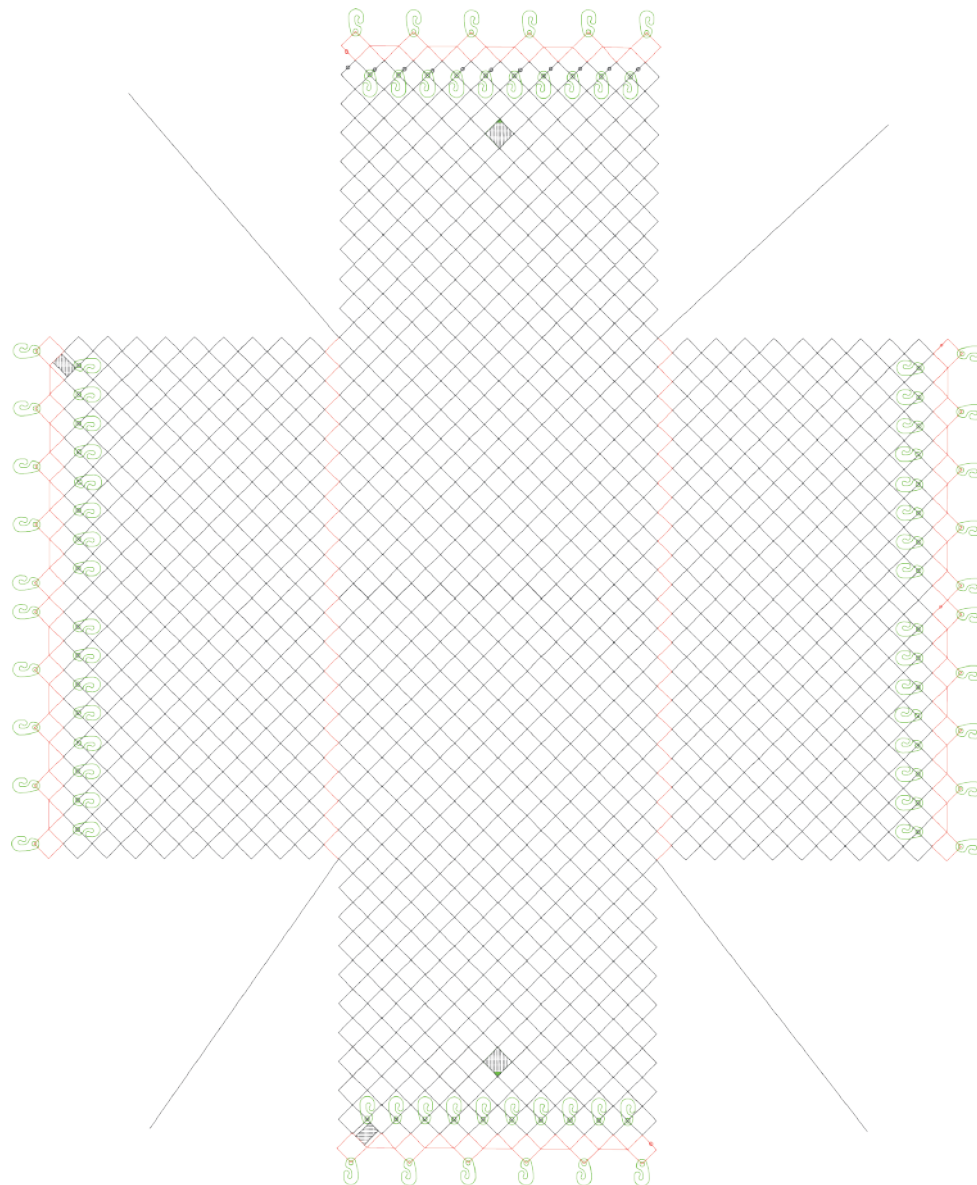

UNDERSLUNG LIFTING NET - 1500 KG / 3300 LBS

UNDERSLUNG LIFTING NET

<b>P/N</b>	GP LN-N15-62X62
<b>NSN</b>	TBD
<b>CONFORMITY</b>	Delivered with certificate of conformance
<b>ULTIMATE LOAD</b>	1497 kg / 3.300 lbs
<b>DIMENSIONS</b>	6,2 x 6,2 m
<b>LOADING PERIMETER</b>	3,5 x 3,5 m
<b>WEBBING</b>	100% Polyester - FAR 25.853
<b>NUMBER OF FITTING RINGS</b>	4 pcs
<b>MESH TYPE</b>	Knotless
<b>MESH DIMENSIONS</b>	125 x 125 mm

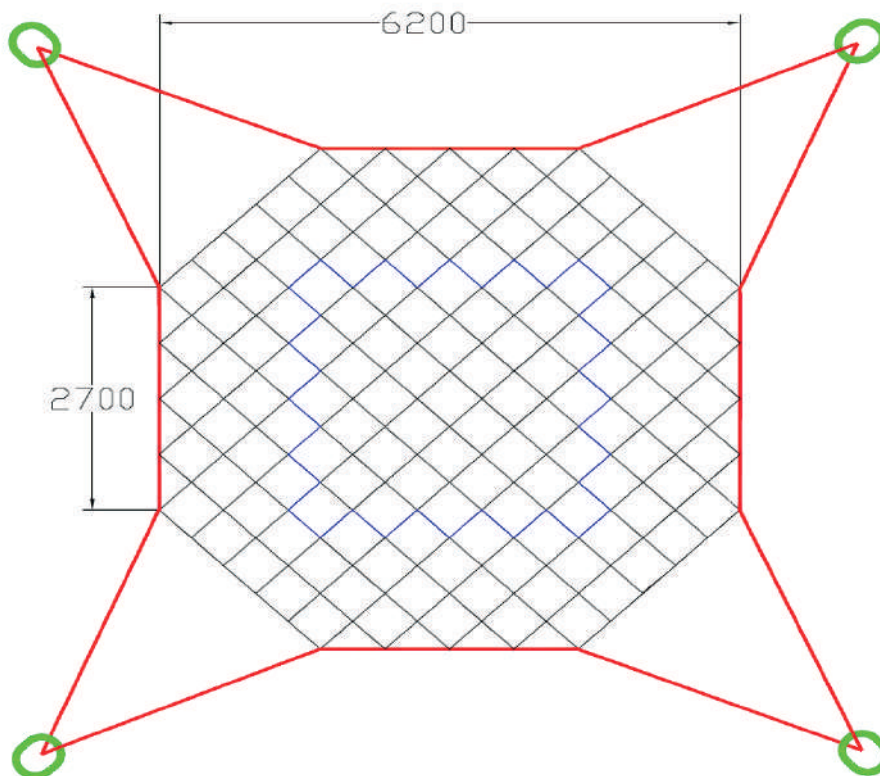

EASA CERTIFIED CARGO NET FOR PMC / PAG PALLET

CARGO NET FOR PMC / PAG PALLET

<b>P/N</b>	<b>2M2N-118-B1-65</b>
<b>NSN</b>	<b>1670-14-559-5545</b>
<b>DESIGN REQUIREMENT</b>	<b>Conform to NAS 3610 and approved ETSO/TSO C90c</b>
<b>ULTIMATE LOAD</b>	6804 kg / 15.000 lbs
<b>DIMENSIONS</b>	88/96" x 125" x 118"
<b>TARE WEIGHT</b>	13 kg / 28 lbs
<b>WEBBING</b>	Polyester - PES
<b>NUMBER OF TIE DOWN STUD</b>	18 pcs
<b>NUMBER OF AJUSTING HOOKS</b>	18 pcs
<b>MESH TYPE</b>	Knotless
<b>MESH DIMENSIONS</b>	250 x 250 mm

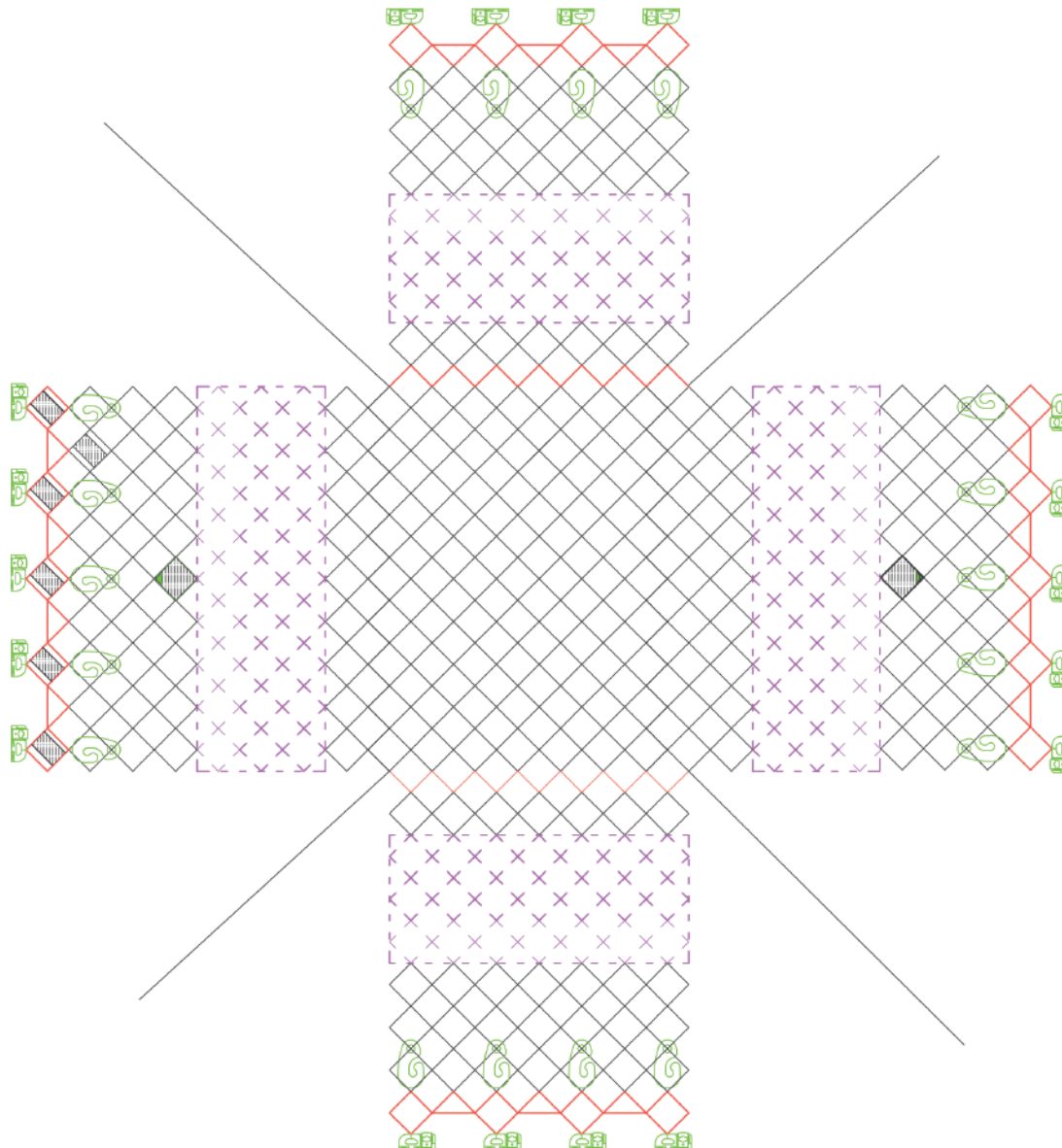

## OTHER PRODUCTS FROM THE FORANKRA GROUP

Road lashing .....	40
One way securing .....	40
Dock equipment .....	41
Lifting .....	41



**ROAD LASHING**

**LASHING LC 2500 daN**

P/N: RHEC6E6E0350900084



**CORNER PROTECT**

**ECO-CORNER**  
P/N: 44973 10 E 240



**HEAVY-CORNER**  
P/N: 05182 11



**ANTISLIP MAT CARGOGRIP**

P/N: TAG5000X250X4-7210



**MULTI-STICK**

P/N: EC049119-10



**LEX-SEAL**

P/N: PLBWL415-LEX



**CABLE-LOCK**

P/N: PLMETAL210

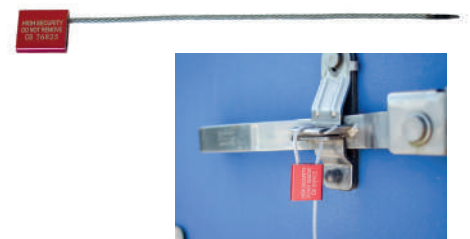

**ONE WAY SECURING**

**AIRGOBAG**

P/N: MATRG90X180-L1VL



**STOP-LOAD**

P/N: SL24MT1535C2

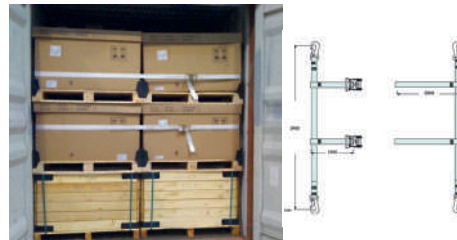

**SAFETY-SHEET**

P/N: SAFETY-SHEET200X220



**CORNER PROTECT ONE USE**

P/N: C0100X100X400-5



**SECU-LOCK**

P/N: PLFDS3



**CONTENEURBLOCK**

P/N: PL1418-17712



**DATA LOGGER**

P/N: TMS110



**THERMAL LINER ISOLEX**

P/N: ISOLEX20-10



**DESICANT ULTRA-DRY**

P/N: ULTRADRY1000-20



**DOCK EQUIPMENT**

**TRAILOR JACK**

P/N: 48780 200



**WHEEL CHOCK**

P/N: 93.951.416.KC



**ALUDOCK**

P/N: PLA1400X550-AL

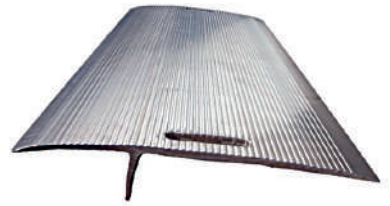

**DOCK LEVELER SPEED-DOCK**

P/N: SPD249X105X76

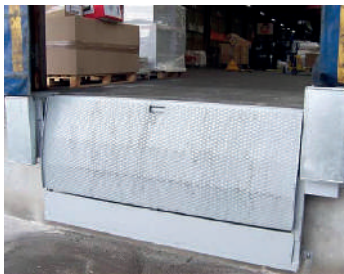

**DOCK LEVELER FLASH-DOCK**

P/N: 48916 10-1065X2000



**BUMPER STEEL-BOX**

P/N: 49107 10 Z



**SLAVE PALLETS /DOLLIES**

CONSULT US



**SECTIONNAL DOOR**

CONSULT US



**TEXTILE BARRER**

CONSULT US



**LIFTING**

**TEXTILE SLING**

CONSULT US



**CHAIN SLING**

CONSULT US

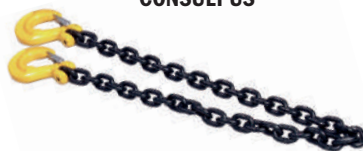

**ACCESSORIES**

CONSULT US



## INDEX

DESIGNATION	P/N	PAGE
PMC/PAG CARGO NET - HEIGHT 64''	2M2N-B2-064-30	9
PMC/PAG CARGO NET - HEIGHT 96''	2M2N-B2-096-30	9
PMC/PAG CARGO NET - HEIGHT 118''	2M2N-B2-118-30	9
PLA CARGO NET - HEIGHT 64''	2L3N-064-B1-21	9
PLA CARGO NET - HEIGHT 80''	2L3N-64-B1-22	9
PKC CARGO NET - HEIGHT 64''	2K3N-064-B1-01	9
PKC CARGO NET - HEIGHT 80''	2K3N-064-B1-02	9
PGA-PGF CARGO NET - HEIGHT 96''	2G1N-096-R2-12	9
PGA-PGF CARGO NET - HEIGHT 118''	2G1N-096-R2-10	9
TIE-DOWN STRAP 2000 lbs	SLTXXXXXXXX	11
TIE-DOWN STRAP 5000 lbs	STXXXXXXXX	11
TIE-DOWN STRAP 10 000 lbs	SHTXXXXXXXX	11
THERMAL COVER	GP T CXXXXXXXX	12
FIRE CONTAINMENT COVER	FCB-096-50 NSN: 4210-14-563-7900	12
VEHICULE STRAP	SR2PL5-400	13
CARGO STOPPER	STP 120/STP140	13
FITTING - SINGLE STUD WITH RING	FS 700	13
FITTING - DOUBLE STUD WITH RING	FS 2000 AP	13
SECURITY SEAL - 1,5 MM	PLSCC15-250	13
SECURITY SEAL - 3,5 MM	PLSCC35-250	13
SECURITY SEAL - 5 MM	PLSCC50-250	13
MULTI STICK	GP MSSS1030	13
ATR 9G BARRIER NET	0110-09-0A-6100EPA GPI: GP AT3000-01	17
ATR 9G BARRIER NET	0110-09-0A-6101EPA GPI: GP AT3010-01	17
ATR 9G BARRIER NET	9000-01-A-6017-F01EPA GPI: GP AT3017-01	17
ATR 9G BARRIER NET	0110-09-0A-6102EPA GPI: GP AT3012	17
ATR 9G BARRIER NET	9000-01-A-6018-F01EPA GPI: GP AT3018	17
SAAB 9G BARRIER NET	25-63-10300 GPI: GP TA151-6	17
SAAB 9G BARRIER NET	25-63-10301-2 GPI: GP TA151-3	17
SAAB 9G BARRIER NET	25-63-10299-1 GPI: GP TA153-1	17
SLOTTED WEBBING 13 MM	723/13B	22
SLOTTED WEBBING 15 MM	723/13R	22
SLOTTED WEBBING 18 MM	723/18	22
FLAT WEBBING 20 MM - ASNA 3573-5919	1163/20	22
FLAT WEBBING 25 MM - ASNA 3573-5926	84 044/25-NO	22
FLAT WEBBING 25 MM - ASNA 3573-5925	98 323/25	22
FLAT WEBBING 25 MM - ASNA 35735925	20 319/25	22

DESIGNATION	P/N	PAGE
FLAT WEBBING 45 MM	0303007/45	22
FLAT WEBBING 48 MM - 2500 daN - BLACK	84 015/50-NO	22
FLAT WEBBING 48 MM - 2500 daN	85 017/50	22
FLAT WEBBING 50 MM - 5000 daN	94 187/50	22
FLAT WEBBING 50 MM - 7500 daN	93 168/50	22
FLAT WEBBING 60 MM - 9000 daN	6592/60	22
FLAT WEBBING 75 MM - 15000 daN	6551/75	22
TUBULAR WEBBING - 15 MM - 1800 daN	724/15	22
VELCRO MALE - ASNA 35461875	AP 800/24-M	22
VELCRO FEMALE - ASNA 35461875	AP 800/24-F	22
GAINÉ	SPB 103	22
STRAP PROTECTION SHEATH	46 137-75	22
TARPOLIN - GREY	32 261 A	23
TARPOLIN - BLUE	32 263 B	23
RASCHEL NETTING	FX 999	23
ANCHOR PLATE	40 000-11	23
DOUBLE ANCHOR PLATE	520 197-40	23
SEAT TRACK	40 456-10	23
SEAT TRACK	40 467-11	23
SEAT TRACK	40 456-51	23
SEAT TRACK	40 986-2000	23
OVER CENTER BUCKLE - 45 MM - 2250 daN	47 800-10	24
ANTI SLIPPAGE OVER CENTER BUCKLE - 45 MM - 2250 daN	48 857-20	24
OVER CENTER BUCKLE - 50 MM - 800 daN	46 067-10	24
OVER CENTER BUCKLE - 25 MM - 2000 daN	42 816-12	24
CAM BUCKLE - 25 MM - 250 daN	41 030-17	24
CAM BUCKLE - 45 MM - 700 daN	42 195-10	24
CAM BUCKLE - 35 MM - 700 daN	48 343-10	24
CAM BUCKLE - 45 MM - 700 daN	40 880-19	24
RATCHET BUCKLE - 25 MM - 750 daN	44 232-10	25
RATCHET BUCKLE - 25 MM - 750 daN - STAINLESS STEEL	44 232-10 SS	25
RATCHET BUCKLE - 25 MM - 2000 daN	43 320-12	25
RATCHET BUCKLE - 50 MM - 5000 daN	46 405-10	25
RATCHET BUCKLE - 50 MM - 5000 daN	44 627-10	25
BUCKLE - 50 MM - 1300 daN	34 900/001	25
RATCHET BUCKLE - 50 MM - 5000 daN	47 105-17	25
SNAP LATCH	45 387-10	25
SLIDE BUCKLE - 25 MM - 800 daN	8023/25	26

## INDEX

DESIGNATION	P/N	PAGE
SLIDE BUCKLE - 50 MM - 900 daN	8023/50	26
SLIDE BUCKLE - 25 MM - 50 daN	34201/251	26
SLIDE BUCKLE - 50 MM - 800 daN	34238/154	26
SLIDE BUCKLE - 30 MM - 150 daN	300 B/C	26
SLIDE BUCKLE - 50 MM - 300 daN	500 B/C	26
SLIDE BUCKLE - 50 daN	34 201/281	26
SLIDE BUCKLE - 150 daN	34 209/271	26
SLIDE BUCKLE - 750 daN	34 238/045	26
SLIDE BUCKLE - 800 daN	34 209/054	26
HOOK - 1100 daN	FS9016	27
HOOK - 900 daN	FS5013	27
HOOK - 450 daN	FS5014	27
HOOK - 5000 daN	349010-16	27
HOOK - 2300 daN	43044-11	27
HOOK - 3500 daN	40084-14	27
HOOK - 5000 daN	40 758-10	27
HOOK - 5000 daN	40 758-11	27
SPECIAL STUD WITH THREAD	40 191-XX	27
LIFTING NET HOOK ASSEMBLY	FS 5018	27
FOOTMAN HOOK - 1000 daN	FS300	28
FOOTMAN HOOK- 800 daN	FS5010	28
FOOTMAN HOOK - 800 daN	FS 5012	28
FOOTMAN LOOP - 900 daN	43 977-10	28
HOOK - 1000 daN	A83	28
HOOK - 800 daN	A85	28
HOOK - 800 daN	A85-01	28
HOOK - 900 daN	A82	28
HOOK - 1200 daN	A84-50	28
CARGO NET FOR NH-90 CARGO COMPARTMENT	GP GAM161613 NSN: 1670-14-578-9654	30
FLOOR FITTING FOR NH-90 CARGO COMPARTMENT	FS 2000 AP NSN: 1670-14-578-966	30
STRAP FOR NH-90 CARGO COMPARTMENT	SMGGLA04005 NSN: 1670-14-578-9659	30
CARGO NET FOR SUPER PUMA AS332 FRONT CARGO COMPARTMENT	GP EUFR225ZA-10	31
CARGO NET FOR SUPER PUMA AS332 REAR CARGO COMPARTMENT	GP EUFR225ZB-10	31
STRAP FOR MILITARY PURPOSES - 2250 KG / 5000 LBS	SIPPL206010-AR NSN: 3940-14-562-4258	33
STRAP FOR MILITARY PURPOSES - 2250 KG / 5000 LBS	SICOL406000	33
STRAP FOR MILITARY PURPOSES - 4450 KG / 10000 LBS	SHZZLC04003	33
STRAP FOR MILITARY PURPOSES - 4450 KG / 10000 LBS	SHTZILD07003-MIL	33

DESIGNATION	P/N	PAGE
TOP PALLET NET HCU-15	GR AR2015-01 NSN: 1670-14-536-6275	34
SIDE PALLET NET HCU-7	GP AR2010-01 NSN: 1670-14-536-6277	34
ONE PIECE CARGO NET FOR HCU-6 PALLET	1B6N-N3-096-12 NSN: 1670-14-563-2143	35
ONE PIECE CARGO NET FOR 2 COUPLED HCU-6 PALLET	1B6N-N3-096-10 NSN: 1670-14-581-2298	36
UNDERSLUNG LIFTING NET	GP LN-N15-62X62	37
EASA CERTIFIED CARGO NET FOR PMC/PAG MILITARY PALLET	2M2N-118-B1-65 NSN: 1670-14-559-5545	38
LASHING LC 2500 daN	RHEC6E6E0350900084	40
ECO-CORNER	44973 10 E 240	40
HEAVY-CORNER	05182 11	40
ANTISLIP MAT CARGOGRIP	TAG5000X250X4-7210	40
MULTI-STICK	ECO49119-10	40
LEX-SEAL	PLBWL415-LEX	40
CABLE-LOCK	PLMETAL210	40
AIRGOBAG	MATR90X180-L1VL	40
STOP-LOAD	SL24MT1535C2	40
SAFETY-SHEET	SAFETY-SHEET200X220	40
CORNER PROTECT ONE USE	CO100X100X400-5	40
SECU-LOCK	PLFDS3	40
DESICANT ULTRA-DRY	ULTRADRY1000-20	40
SEAL CONTENEURBLOCK	PL1418-17712	40
DATA LOGGER	TMS110	40
THERMAL LINER ISOLEX	ISOLEX20-10	40
TRAILOR JACK	48780 200	41
WHEEL CHOCK	93.951.416.KC	41
ALUDOCK	PLA1400X550-AL	41
DOC LEVELER SPEED-DOCK	SPD249X105X76	41
DOC LEVELER FLASH-DOCK	48916 10-1065X2000	41
BUMPER STEEL-BOX	49107 10Z	41
SLAVE PALLETS / DOLLIES	CONSULT US	41
SECTIONNAL DOOR	CONSULT US	41
TEXTILE BARRER	CONSULT US	41
TEXTILE SLING	CONSULT US	41
CHAIN SLING	CONSULT US	41
ACCESSORIES	CONSULT US	41

Restraint solutions  
for the aerospace industry



ZA la Bohalle  
49800 La Bohalle - FRANCE  
Office: +33 (0)2 41 54 90 60  
Fax: +33 (0)2 41 80 49 82  
[gpi@gpi-int.fr](mailto:gpi@gpi-int.fr)

[www.gpi-int.fr](http://www.gpi-int.fr)